

LINK
TECHNOLOGIES
WIRELESS MADE SIMPLE

**Q4
11**

Product Overview Guide

Welcome to the Products & Services of



Phone: (541) 471-6256
Fax: (541) 471-6251
www.linxtechnologies.com
info@linxtechnologies.com

About Linx

From all of us here at Linx Technologies, thank you for your interest in learning more about our rapidly growing company. The following section will provide a brief insight into our history, vision, and future.

Our History

Founded in 1996, Linx Technologies is a privately-held growth-mode corporation that specializes in low-cost wireless modules, OEM RF product solutions, and standard and custom connectors and cable assemblies for high-volume OEM applications. The Antenna Factor division specializes in cost-effective standard and custom antennas for consumer and industrial wireless products.

Our Vision

Radio Frequency (RF) is a complex science requiring a unique grasp of both advanced technical issues and complex legal requirements; thus, adding wireless capabilities to a product has traditionally been a costly and time-consuming proposition. This has limited the widespread use of RF and prevented many potentially useful products from reaching production.

Here at Linx, we believe that every engineer, regardless of training and experience, should have the option of using RF technology. That's why "Wireless Made Simple" is more than just a motto, it's our commitment. A commitment to offering the highest quality RF products designed to provide a simple and cost-effective path to making any product wireless.

Linx Technologies is positioned to take advantage of the exploding wireless market it helped to create. We believe that our vision for enabling engineers of all skill levels in diverse industries to harness the power of RF will allow Linx continued recognition as a leader in RF solutions.

Table of Contents

	PAGE	SECTION
RF MODULES	4	1
RF MODULE DEVELOPMENT SYSTEMS	33	2
RF AMPLIFIERS	43	3
INTERFACE MODULES	47	4
INTEGRATED CIRCUITS	53	5
PRE-CERTIFIED OEM PRODUCTS	71	6
CONNECTORS	91	7
ANTENNAS	109	8
ADDITIONAL SERVICES	139	9
APPLICATIONS LITERATURE	143	10
TERMS AND CONDITIONS	144	11

1 RF MODULES

Series	Part Number	Frequency (MHz)	Vcc (V)	Icc (mA) Typ.	Analog Range	Max. Data Rate (bps)	Package	Page
TRANSMITTERS								
LC	TXM-315-LC	315	2.7 - 5.2	3.0	N/A	5,000	SMD	10
	TXM-418-LC	418	2.7 - 5.2	3.0	N/A	5,000	SMD	10
	TXM-433-LC	433.92	2.7 - 5.2	3.0	N/A	5,000	SMD	10
LR	TXM-315-LR	315	2.1 - 3.6	3.4	N/A	10,000	SMD	12
	TXM-418-LR	418	2.1 - 3.6	3.4	N/A	10,000	SMD	12
	TXM-433-LR	433.92	2.1 - 3.6	3.4	N/A	10,000	SMD	12
KH2	TXE-315-KH2	315	2.7 - 5.2	1.5	N/A	5,000	SMD	16
	TXE-418-KH2	418	2.7 - 5.2	1.5	N/A	5,000	SMD	16
	TXE-433-KH2	433.92	2.7 - 5.2	1.5	N/A	5,000	SMD	16
ES	TXM-869-ES	869.85	2.1 - 4.0	7.0	20Hz - 28kHz	56,000	SMD	20
	TXM-916-ES	916.48	2.1 - 4.0	7.0	20Hz - 28kHz	56,000	SMD	20
HP3	TXM-900-HP3-PPO	902 - 928	2.8 - 13.0	14.0	50Hz - 28kHz	56,000	SIP	24
	TXM-900-HP3-PPS	902 - 928	2.8 - 13.0	14.0	50Hz - 28kHz	56,000	SIP	24
	TXM-900-HP3-SPO	902 - 928	2.8 - 13.0	14.0	50Hz - 28kHz	56,000	SMD	24
	TXM-900-HP3-SPS	902 - 928	2.8 - 13.0	14.0	50Hz - 28kHz	56,000	SMD	24
RECEIVERS								
LR	RXM-315-LR	315	2.7 - 3.6	5.2	50Hz - 5kHz	10,000	SMD	14
	RXM-418-LR	418	2.7 - 3.6	5.2	50Hz - 5kHz	10,000	SMD	14
	RXM-433-LR	433.92	2.7 - 3.6	5.2	50Hz - 5kHz	10,000	SMD	14
KH2	RXD-315-KH2	315	2.7 - 3.6	5.2	50Hz - 5kHz	10,000	SMD	18
	RXD-418-KH2	418	2.7 - 3.6	5.2	50Hz - 5kHz	10,000	SMD	18
	RXD-433-KH2	433.92	2.7 - 3.6	5.2	50Hz - 5kHz	10,000	SMD	18
ES	RXM-869-ES	869.85	4.5 - 5.5	6.0	20Hz - 28kHz	56,000	SMD	22
	RXM-916-ES	916.48	4.5 - 5.5	6.0	20Hz - 28kHz	56,000	SMD	22
HP3	RXM-900-HP3-PPO	902 - 928	2.8 - 13.0	19.0	50Hz - 28kHz	56,000	SIP	26
	RXM-900-HP3-PPS	902 - 928	2.8 - 13.0	19.0	50Hz - 28kHz	56,000	SIP	26
	RXM-900-HP3-SPO	902 - 928	2.8 - 13.0	19.0	50Hz - 28kHz	56,000	SMD	26
	RXM-900-HP3-SPS	902 - 928	2.8 - 13.0	19.0	50Hz - 28kHz	56,000	SMD	26
TRANSCEIVERS								
LT	TRM-315-LT	315	2.1 - 3.6	9.5 / 7.9	N/A	10,000	SMD	6
	TRM-418-LT	418	2.1 - 3.6	9.5 / 7.9	N/A	10,000	SMD	6
	TRM-433-LT	433.92	2.1 - 3.6	9.5 / 7.9	N/A	10,000	SMD	6
GPS RECEIVERS								
SG	RXM-GPS-SG	1575.42	3.0 - 4.2	46 \ 28	N/A	N/A	SMD	28
SR	RXM-GPS-SR	1575.42	3.0 - 4.2	49	N/A	N/A	SMD	30

Wireless Made Simple®!



Linx RF modules make it easy and cost-effective to add wireless capabilities to your product. That's because Linx modules contain all the components necessary for the transmission of RF. Since no external components (except an antenna) are needed, the modules are easily applied, even by persons without previous RF design experience. This conserves valuable engineering resources and greatly reduces the product's time to market. Once in production, the savings continue because Linx RF modules improve production yields, reduce placement costs, and require no production testing or adjustment.

RF MODULES

PART #	DESCRIPTION	PG.
TRM-***-LT	LT Series Transceiver	6
TXM-***-LC	LC Series Transmitter	10
TXM-***-LR	LR Series Transmitter	12
RXM-***-LR	LR Series Receiver	14
TXE-***-KH2	KH2 Series Transmitter	16
RXD-***-KH2	KH2 Series Receiver	18
TXM-***-ES	ES Series Transmitter	20
RXM-***-ES	ES Series Receiver	22
TXM-900-HP3	HP3 Series Transmitter	24
RXM-900-HP3	HP3 Series Receiver	26
RXM-GPS-SG	SG Series GPS Receiver	28
RXM-GPS-SR	SR Series GPS Receiver	30

Please Note: The part numbers in this table and the “***” in the ordering information boxes on the pages following represent the three most significant numbers of the part's actual frequency.



DESCRIPTION

The LT Series transceiver is ideal for the bi-directional wireless transfer of serial data, control, or command information in the favorable 260-470MHz band. The transceiver is capable of generating +10dBm into a 50-ohm load and achieves an outstanding typical sensitivity of -112dBm. Its advanced synthesized architecture delivers outstanding stability and frequency accuracy, and minimizes the effects of antenna pulling. When paired, the transceivers form a reliable wireless link that is capable of transferring data at rates of up to 10,000bps over distances of up to 3,000 feet. Applications operating over shorter distances or at lower data rates will also benefit from increased link reliability and superior noise immunity. Housed in a tiny reflow-compatible SMD package, the transceiver requires no external RF components (except an antenna), which greatly simplifies integration and lowers assembly costs.

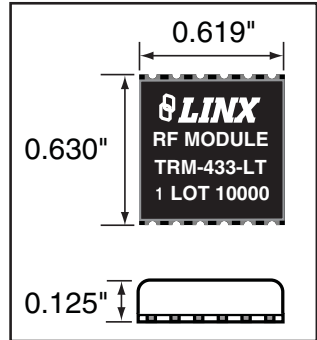

PHYSICAL DIMENSIONS

FEATURES

- Long range
- Low cost
- PLL-synthesized architecture
- Direct serial interface
- Data rates to 10,000bps
- No external RF components required
- Low power consumption
- Compact surface-mount package
- Wide temperature range
- RSSI and power-down functions
- No production tuning
- Easy to use

APPLICATIONS INCLUDE

- 2-Way Remote Control
- Keyless Entry
- Garage / Gate Openers
- Lighting Control
- Medical Monitoring / Call Systems
- Remote Industrial Monitoring
- Periodic Data Transfer
- Home / Industrial Automation
- Remote Status / Position Sensing
- Fire / Security Alarms / Access Control
- Long-Range RFID
- Wire Elimination

ORDERING INFORMATION

PART #	DESCRIPTION
TRM-315-LT	Transceiver 315MHz
TRM-418-LT	Transceiver 418MHz
TRM-433-LT	Transceiver 433MHz
EVAL-***-LT	Basic Evaluation Kit
*** = Frequency	
Transceivers are supplied in tubes of 34pcs.	

ELECTRICAL SPECIFICATIONS

Parameter	Designation	Min.	Typical	Max.	Units	Notes
POWER SUPPLY						
Operating Voltage	V_{CC}	2.1	3.0	3.6	VDC	–
Supply Current	I_{CC}					
Transmit Mode Logic High		–	12	14	mA	1
Transmit Mode Logic High		–	7.6	9.5	mA	2
Transmit Mode Logic Low		–	4.0	5.0	mA	–
Receive Mode		–	6.1	7.9	mA	–
Power Down Current	I_{PDN}	–	11.5	20.0	μ A	9,10
DATA Line:						
Output Low Voltage	V_{OL}	–	0.15	–	VDC	3
Output High Voltage	V_{OH}	–	$V_{CC}-0.26$	–	VDC	4
Input Low Threshold	V_{IL}	–	–	$0.1V_{CC}$	VDC	5
Input High Threshold	V_{IH}	$0.9V_{CC}$	–	–	VDC	–
Power Down Input:						
Input Low Threshold	V_{IL}	–	–	$0.1V_{CC}$	VDC	5
Input High Threshold	V_{IH}	$0.9V_{CC}$	–	–	VDC	–
RF SECTION						
Frequency Range:	F_C					
TRM-315-LT		–	315	–	MHz	–
TRM-418-LT		–	418	–	MHz	–
TRM-433-LT		–	433.92	–	MHz	–
Center Frequency Accuracy	–	-50	–	+50	kHz	–
Data Rate	–	65	–	10,000	bps	–
RECEIVER SECTION						
LO Feedthrough	–	–	-80	–	dBm	6,9
IF Frequency	F_{IF}	–	10.7	–	MHz	9
Noise Bandwidth	N_{3DB}	–	280	–	kHz	9
Receiver Sensitivity	–	-108	-112	-118	dBm	7
RSSI / Analog:						
Dynamic Range	–	–	80	–	dB	9
Analog Bandwidth	–	20	–	5,000	Hz	9
Gain	–	–	15	–	mV / dB	9
Voltage with No Carrier	–	–	430	–	mV	9
TRANSMITTER SECTION						
Output Power	P_O	–	+9.2	+11	dBm	1,6
With a 750 Ω resistor on LADJ	P_O	-4	0.0	+4	dBm	2,6
Output Power Control Range	–	-30	–	MAX	dB	9
Harmonic Emissions	P_H	-36	–	–	dBc	6
ANTENNA PORT						
RF Input Impedance	R_{IN}	–	50	–	Ω	9
TIMING						
Receiver Turn-On Time:						
Via V_{CC}	–	–	2.2	–	mSec	8,9
Via PDN	–	–	0.25	–	mSec	8,9
Max. Time Between Transitions	–	–	15.0	–	mSec	9
Transmitter Turn-On Time:						
Via V_{CC}	–	–	2.0	–	mSec	9
Via PDN	–	–	–	500	μ Sec	9
Modulation Delay	–	–	–	30.0	nS	9
Transmit to Receive Switch Time	–	–	180	400	μ Sec	9
Receive to Transmit Switch Time	–	–	490	1000	μ Sec	9
Dwell Time	–	290	–	–	μ Sec	9,11
ENVIRONMENTAL						
Operating Temperature Range	–	-40	–	+85	$^{\circ}$ C	9

ELECTRICAL SPECIFICATIONS

(Continued from previous page)

Notes

1. With a 0Ω resistor on LADJ.
2. With a 750Ω resistor on LADJ.
3. $I_{SINK} = 500\mu A$.
4. $I_{SOURCE} = 500\mu A$.
5. $I_{SINK} = 20\mu A$.
6. Into a 50-ohm load.
7. With a 50% square wave at 1,000bps.
8. Time to valid data output.
9. Characterized, but not tested.
10. Receive Mode on power down (see Using the PDN Line section)
11. Minimum time before mode change

ABSOLUTE MAXIMUM RATINGS

Supply Voltage V_{CC}	-0.3	to	+4.0	VDC
Any Input or Output Pin	-0.3	to	$V_{CC}+0.3$	VDC
RF Input			0	dBm
Operating Temperature	-40	to	+85	°C
Storage Temperature	-65	to	+150	°C
Soldering Temperature	+260°C for 10 seconds			

NOTE Exceeding any of the limits of this section may lead to permanent damage to the device. Furthermore, extended operation at these maximum ratings may reduce the life of this device.



DESCRIPTION

The LC Series is ideally suited for volume use in OEM applications such as remote control, security, identification, and periodic data transfer. Housed in a compact surface-mount package, the LC Series transmitter utilizes a highly-optimized SAW architecture to achieve an unmatched blend of performance, size, efficiency, and cost. When paired with a matching LR Series receiver, a highly reliable wireless link is formed, capable of transferring serial data at rates of up to 5,000bps over distances of up to 3,000 feet. No external RF components are required (except an antenna), making design and integration straightforward, even for engineers without previous RF experience.

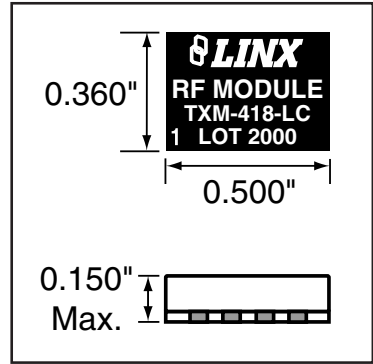

PHYSICAL DIMENSIONS

FEATURES

- Low cost
- No external RF components required
- Ultra-low power consumption
- Compact surface-mount package
- Stable SAW-based architecture
- Supports data rates to 5,000bps
- Wide supply range (2.7 to 5.2VDC)
- Direct serial interface
- Low harmonics
- No production tuning

APPLICATIONS INCLUDE

- Remote Control
- Keyless Entry
- Garage / Gate Openers
- Lighting Control
- Medical Monitoring / Call Systems
- Remote Industrial Monitoring
- Periodic Data Transfer
- Home / Industrial Automation
- Fire / Security Alarms
- Remote Status Sensing
- Long-Range RFID
- Wire Elimination

ORDERING INFORMATION

PART #	DESCRIPTION
TXM-315-LC	Transmitter 315MHz
TXM-418-LC	Transmitter 418MHz
TXM-433-LC	Transmitter 433MHz
RXM-315-LR	Receiver 315MHz
RXM-418-LR	Receiver 418MHz
RXM-433-LR	Receiver 433MHz
EVAL-***-LC	Basic Evaluation Kit
*** = Frequency	
LC transmitters are supplied in tubes of 50pcs.	

ELECTRICAL SPECIFICATIONS

Parameter	Designation	Min.	Typical	Max.	Units	Notes
POWER SUPPLY						
Operating Voltage	V_{CC}	2.7	–	5.2	VDC	–
Supply Current	I_{CC}	–	3.0	6.0	mA	1,4
Power-Down Current	I_{PDN}	–	–	1.5	μ A	2
TRANSMITTER SECTION						
Transmit Frequency:	F_C					
TXM-315-LC		–	315	–	MHz	–
TXM-418-LC		–	418	–	MHz	–
TXM-433-LC		–	433.92	–	MHz	–
Center Frequency Accuracy	–	-75	–	+75	kHz	–
Output Power	P_o	-4	0	+4	dBm	3
Harmonic Emissions	P_H	–	–	-36	dBc	3
Data Rate	–	100	–	5,000	bps	–
Data Input:						
Logic Low	V_{IL}	0.0	–	0.4	VDC	–
Logic High	V_{IH}	2.5	–	V_{CC}	VDC	–
ANTENNA PORT						
RF Output Impedance	R_{OUT}	–	50	–	Ω	5
TIMING						
Transmitter Turn-On Time	–	–	30	80	μ Sec	3
Transmitter Turn-Off Time	–	–	–	100	nSec	–
ENVIRONMENTAL						
Operating Temperature Range	–	-30	–	+70	$^{\circ}$ C	5

Notes

1. Current draw with DATA pin held continuously high.
2. Current draw with DATA pin low.
3. RF out connected to a 50 Ω load.
4. LADJ through 430 Ω resistor.
5. Characterized, but not tested.

ABSOLUTE MAXIMUM RATINGS

Supply Voltage V_{CC}	-0.3	to	+6.0	VDC
Any Input or Output Pin	-0.3	to	V_{CC}	VDC
Operating Temperature	-30	to	+70	$^{\circ}$ C
Storage Temperature	-45	to	+85	$^{\circ}$ C
Soldering Temperature	+225 $^{\circ}$ C for 10 seconds			
<p>*NOTE* Exceeding any of the limits of this section may lead to permanent damage to the device. Furthermore, extended operation at these maximum ratings may reduce the life of this device.</p>				



DESCRIPTION

The LR Series transmitter is ideal for the cost-effective wireless transfer of serial data, control, or command information in the favorable 260-470MHz band. When paired with a compatible Linx receiver, a reliable wireless link is formed, capable of transferring serial data at rates of up to 10,000bps at distances of up to 3,000 feet. Applications operating over shorter distances or at lower data rates will also benefit from increased link reliability and superior noise immunity. The transmitter's synthesized architecture delivers outstanding stability and frequency accuracy and minimizes the affects of antenna pulling. Housed in a tiny reflow-compatible SMD package, the transmitter requires no external RF components (except an antenna), which greatly simplifies integration and lowers assembly costs.

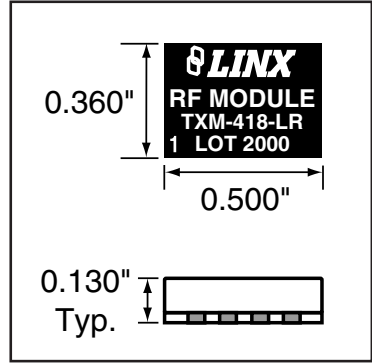

PHYSICAL DIMENSIONS

FEATURES

- Long range
- Low cost
- PLL synthesized architecture
- Direct serial interface
- Data rates to 10,000bps
- No external RF components required
- Low power consumption
- Low supply voltage (2.1 to 3.6VDC)
- Compact surface mount package
- Wide temperature range
- Power-down function
- No production tuning

APPLICATIONS INCLUDE

- Remote Control
- Keyless Entry
- Garage / Gate Openers
- Lighting Control
- Medical Monitoring / Call Systems
- Remote Industrial Monitoring
- Periodic Data Transfer
- Home / Industrial Automation
- Fire / Security Alarms
- Remote Status / Position Sensing
- Long-Range RFID
- Wire Elimination

ORDERING INFORMATION

PART #	DESCRIPTION
TXM-315-LR	Transmitter 315MHz
TXM-418-LR	Transmitter 418MHz
TXM-433-LR	Transmitter 433MHz
RXM-315-LR	Receiver 315MHz
RXM-418-LR	Receiver 418MHz
RXM-433-LR	Receiver 433MHz
EVAL-***-LR	Basic Evaluation Kit
*** = Frequency	
LR transmitters are supplied in tubes of 50pcs.	

ELECTRICAL SPECIFICATIONS

Parameter	Designation	Min.	Typical	Max.	Units	Notes
POWER SUPPLY						
Operating Voltage	V_{CC}	2.1	3.0	3.6	VDC	–
Supply Current:	I_{CC}	–	3.4	–	mA	1,2
Logic High		–	5.1	–	mA	2
Logic Low		–	1.8	–	mA	–
Power-Down Current	I_{PDN}	–	5.0	–	nA	–
TRANSMITTER SECTION						
Transmit Frequency:	F_C					
TXM-315-LR		–	315	–	MHz	–
TXM-418-LR		–	418	–	MHz	–
TXM-433-LR		–	433.92	–	MHz	–
Center Frequency Accuracy	–	-50	–	+50	kHz	–
Output Power	P_O	-4	0	+4	dBm	2
Output Power Control Range	–	-80	–	+10	dB	3
Harmonic Emissions	P_H	–	–	-36	dBc	–
Data Rate	–	DC	–	10,000	bps	–
Data Input:						
Logic Low	–	–	–	0.25	VDC	–
Logic High	–	$V_{CC}-0.25$	–	–	VDC	–
Power-Down Input:						
Logic Low	–	–	–	0.25	VDC	–
Logic High	–	$V_{CC}-0.25$	–	–	VDC	–
ANTENNA PORT						
RF Output Impedance	R_{OUT}	–	50	–	Ω	4
TIMING						
Transmitter Turn-On Time:						
Via V_{CC} or PDN	–	–	1.0	–	mSec	4
Modulation Delay	–	–	–	30	nS	4
ENVIRONMENTAL						
Operating Temperature Range	–	-40	–	+85	$^{\circ}C$	4

Notes

1. With a 50% duty cycle.
2. With a 750 Ω resistor on LADJ.
3. See graph on Page 3 of the LR Series Transmitter Data Guide.
4. Characterized, but not tested.

ABSOLUTE MAXIMUM RATINGS

Supply Voltage V_{CC}	-0.3	to	+3.6	VDC
Any Input or Output Pin	-0.3	to	$V_{CC} + 0.3$	VDC
Operating Temperature	-40	to	+85	$^{\circ}C$
Storage Temperature	-40	to	+90	$^{\circ}C$
Soldering Temperature	+225 $^{\circ}C$ for 10 seconds			

NOTE Exceeding any of the limits of this section may lead to permanent damage to the device. Furthermore, extended operation at these maximum ratings may reduce the life of this device.



DESCRIPTION

The LR Receiver is ideal for the wireless transfer of serial data, control, or command information in the favorable 260-470MHz band. The receiver's advanced synthesized architecture achieves an outstanding typical sensitivity of -112dBm, which provides a 5 to 10 times improvement in range over previous solutions. When paired with a compatible Linx transmitter, a reliable wireless link is formed capable of transferring serial data at rates of up to 10,000bps at distances of up to 3,000 feet. Applications operating over shorter distances or at lower data rates will also benefit from increased link reliability and superior noise immunity. Housed in a tiny reflow-compatible SMD package, the LR Receiver module is footprint-compatible with the popular LC-S Receiver, allowing existing users an instant path to improved range and lower cost. No external RF components are required (except an antenna), allowing for easy integration, even for engineers without previous RF experience.

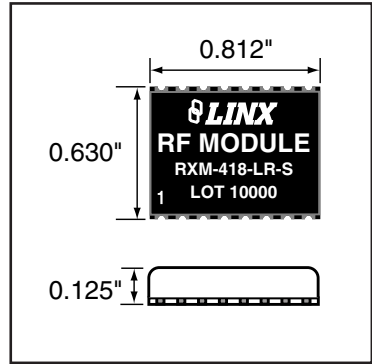

PHYSICAL DIMENSIONS

FEATURES

- Long range
- Low cost
- PLL synthesized architecture
- Direct serial interface
- Data rates to 10,000bps
- Qualified data output
- Low power consumption
- No external RF components required
- Low supply voltage (2.7-3.6VDC)
- Compact SMD package
- Wide temperature range
- RSSI and power-down
- No production tuning

APPLICATIONS INCLUDE

- Remote Control
- Keyless Entry
- Garage / Gate Openers
- Lighting Control
- Medical Monitoring / Call Systems
- Remote Industrial Monitoring
- Periodic Data Transfer
- Home / Industrial Automation
- Fire / Security Alarms
- Remote Status / Position Sensing
- Long-Range RFID
- Wire Elimination

ORDERING INFORMATION

PART #	DESCRIPTION
TXM-315-LR	Transmitter 315MHz
TXM-418-LR	Transmitter 418MHz
TXM-433-LR	Transmitter 433MHz
RXM-315-LR	Receiver 315MHz
RXM-418-LR	Receiver 418MHz
RXM-433-LR	Receiver 433MHz
EVAL-***-LR	Basic Evaluation Kit

*** = Frequency

LR receivers are supplied in tubes of 25pcs.

ELECTRICAL SPECIFICATIONS

Parameter	Designation	Min.	Typical	Max.	Units	Notes
POWER SUPPLY						
Operating Voltage	V_{CC}	2.7	3.0	3.6	VDC	–
With Dropping Resistor		4.3	5.0	5.2	VDC	1,5
Supply Current	I_{CC}	4.0	5.2	7.0	mA	–
Power-Down Current	I_{PDN}	20.0	28.0	35.0	μ A	5
RECEIVER SECTION						
Receive Frequency:	F_c					
RXM-315-LR		–	315	–	MHz	–
RXM-418-LR		–	418	–	MHz	–
RXM-433-LR		–	433.92	–	MHz	–
Center Frequency Accuracy	–	-50	–	+50	kHz	–
LO Feedthrough	–	–	-80	–	dBm	2,5
IF Frequency	–	–	10.7	–	MHz	5
Noise Bandwidth	N_{dB}	–	280	–	kHz	–
Data Rate	–	100	–	10,000	bps	–
Data Output:						
Logic Low	–	0.0	–	0.4	VDC	3
Logic High	–	$V_{CC}-0.4$	–	V_{CC}	VDC	3
Receiver Sensitivity	–	-106	-112	-118	dBm	4
RSSI / Analog:						
Dynamic Range	–	–	80	–	dB	5
Analog Bandwidth	–	50	–	5,000	Hz	5
Gain	–	–	16.0	–	mV/dB	5
Voltage With No Carrier	–	–	1.5	–	V	5
ANTENNA PORT						
RF Input Impedance	R_{IN}	–	50	–	Ω	5
TIMING						
Receiver Turn-On Time:						
Via V_{CC}	–	3.0	7.0	10.0	mSec	5,6
Via PDN	–	0.04	0.25	0.5	mSec	5,6
Max. Time Between Transitions	–	–	10.0	–	mSec	5
ENVIRONMENTAL						
Operating Temperature Range	–	-40	–	+70	$^{\circ}$ C	5

Notes

1. The LR can utilize a 4.3 to 5.2VDC supply provided a 330-ohm resistor is placed in series with V_{CC} .
2. Into a 50-ohm load.
3. When operating from a 5V source, it is important to consider that the output will swing to well less than 5 volts as a result of the required dropping resistor. Please verify that the minimum voltage will meet the high threshold requirement of the device to which data is being sent.
4. For BER of 10^{-5} at 1,200bps.
5. Characterized, but not tested.
6. Time to valid data output.

ABSOLUTE MAXIMUM RATINGS

Supply Voltage V_{CC}	-0.3	to	+3.6	VDC
Supply Voltage V_{CC} Using Resistor	-0.3	to	+5.2	VDC
Any Input or Output Pin	-0.3	to	+3.6	VDC
RF Input			0	dBm
Operating Temperature	-40	to	+70	$^{\circ}$ C
Storage Temperature	-45	to	+85	$^{\circ}$ C
Soldering Temperature	+225 $^{\circ}$ C for 10 seconds			

NOTE Exceeding any of the limits of this section may lead to permanent damage to the device. Furthermore, extended operation at these maximum ratings may reduce the life of this device.



RF TRANSMITTER WITH INTEGRATED ENCODER

DESCRIPTION

The KH2 Series is ideally suited for volume use in OEM applications such as remote control and command, and keyless entry. Housed in a compact SMD package, it combines a highly-optimized RF transmitter with an on-board encoder. When paired with a matching KH2 Series receiver / decoder module, a reliable wireless link is formed, capable of transferring the status of 8 parallel inputs over distances of up to 3,000 feet. Ten tri-state address lines provide 59,049 (3¹⁰) addresses for security and uniqueness. No external RF components are required (except an antenna), making integration straightforward.

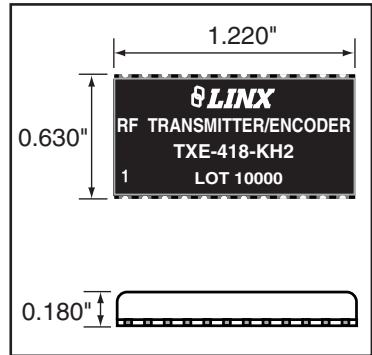

PHYSICAL DIMENSIONS

FEATURES

- Low cost
- On-board encoder
- 8 parallel binary inputs
- 3¹⁰ addresses for security and uniqueness
- No external RF components required
- Ultra-low power consumption
- Compact SMD Package
- Stable SAW-based architecture
- Adjustable output power
- Transmit enable line
- No production tuning

APPLICATIONS INCLUDE

- Remote Control / Command
- Keyless Entry
- Garage / Gate Openers
- Lighting Control
- Call Systems
- Home / Industrial Automation
- Fire / Security Alarms
- Remote Status Monitoring
- Wire Elimination

ORDERING INFORMATION

PART #	DESCRIPTION
TXE-315-KH2	Transmitter 315MHz
TXE-418-KH2	Transmitter 418MHz
TXE-433-KH2	Transmitter 433MHz
RXD-315-KH2	Receiver 315MHz
RXD-418-KH2	Receiver 418MHz
RXD-433-KH2	Receiver 433MHz
EVAL-***-KH2	Basic Evaluation Kit
*** = Frequency	
KH2 transmitters are supplied in tubes of 20pcs.	

ELECTRICAL SPECIFICATIONS

Parameter	Designation	Min.	Typical	Max.	Units	Notes
POWER SUPPLY						
Operating Voltage	V_{CC}	2.7	–	5.2	VDC	–
Supply Current	I_{CC}	–	1.5	–	mA	1,4
Power-Down Current	I_{PDN}	–	1.0	–	μ A	–
TRANSMITTER SECTION						
Transmit Frequency:	F_C					
TXE-315-KH2		–	315	–	MHz	–
TXE-418-KH2		–	418	–	MHz	–
TXE-433-KH2		–	433.92	–	MHz	–
Center Frequency Accuracy	–	-75	–	+75	kHz	–
Output Power	P_O	-4	+2	+4	dBm	2,3
Harmonic Emissions:	P_H					
TXE-315-KH2		-40	–	–	dBc	–
TXE-418-KH2		-40	–	–	dBc	–
TXE-433-KH2		-45	–	–	dBc	–
ANTENNA PORT						
RF Output Impedance	R_{OUT}	–	50	–	Ω	4
ENCODER						
Data Length	–	–	26 bits 3x	–	–	–
Average Data Duty Cycle	–	–	50%	–	–	4
Encoder Oscillator	F_{ENC}	–	70	–	kHz	4
Data Input:						
Logic Low	V_{IL}	0	–	$0.2 \times V_{CC}$	VDC	4
Logic High	V_{IH}	$V_{CC} \times 0.8$	–	V_{CC}	VDC	4
Input Sink Current	–	0.6	1.0	1.2	mA	4
ENVIRONMENTAL						
Operating Temperature Range	–	-30	–	+70	$^{\circ}$ C	4

Notes

1. Current draw with 50% mark / space ratio.
2. Into a 50 Ω load.
3. With 430 Ω resistor on LADJ.
4. Characterized, but not tested.

ABSOLUTE MAXIMUM RATINGS

Supply Voltage V_{CC}	-0.3	to	+6.0	VDC
Any Input or Output Pin	-0.3	to	V_{CC}	VDC
Operating Temperature	-30	to	+70	$^{\circ}$ C
Storage Temperature	-45	to	+85	$^{\circ}$ C
Soldering Temperature	+225 $^{\circ}$ C for 10 seconds			

NOTE Exceeding any of the limits of this section may lead to permanent damage to the device. Furthermore, extended operation at these maximum ratings may reduce the life of this device.



RF RECEIVER WITH INTEGRATED DECODER

DESCRIPTION

The KH2 Series is ideally suited for volume use in OEM applications such as remote control / command and keyless entry. It combines a high-performance RF receiver with an on-board decoder. When paired with a matching KH Series transmitter / encoder module, OEM transmitter, or LC or LR Series transmitter and Holtek HT640 encoder combination, a highly reliable wireless link is formed, capable of transferring the status of 8 parallel inputs for distances of up to 3,000 feet. Ten tri-state address lines provide 59,049 (3¹⁰) different addresses for security and uniqueness. Housed in a compact SMD package, the KH2 module utilizes an advanced synthesized architecture to achieve an unmatched blend of performance, size, range, and cost. No external RF components, are required (except an antenna), making design integration straightforward.

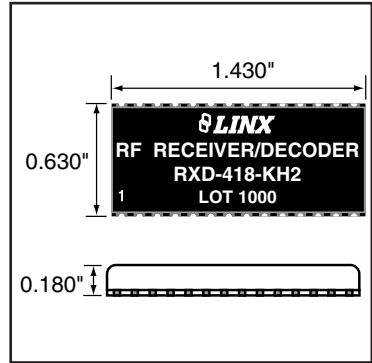

PHYSICAL DIMENSIONS

FEATURES

- Low cost
- Long range
- On-board decoder
- 8 parallel binary outputs
- 3¹⁰ addresses for security and uniqueness
- Ultra-low power consumption
- Compact SMD package
- Advanced synthesized architecture
- Received data output
- Transmission validation
- No production tuning
- No external RF components required (except an antenna)
- Pin-compatible with original KH

APPLICATIONS INCLUDE

- Remote Control / Command
- Keyless Entry
- Garage / Gate Openers
- Lighting Control
- Call Systems
- Home / Industrial Automation
- Fire / Security Alarms
- Remote Status Monitoring
- Wire Elimination

ORDERING INFORMATION

PART #	DESCRIPTION
TXE-315-KH	Transmitter / Encoder 315MHz
TXE-418-KH	Transmitter / Encoder 418MHz
TXE-433-KH	Transmitter / Encoder 433MHz
RXD-315-KH2	Receiver / Decoder 315MHz
RXD-418-KH2	Receiver / Decoder 418MHz
RXD-433-KH2	Receiver / Decoder 433MHz
EVAL-***-KH2	Basic Evaluation Kit
*** = Frequency	
KH2 receivers are supplied in tubes of 20 pcs.	

ELECTRICAL SPECIFICATIONS

Parameter	Designation	Min.	Typical	Max.	Units	Notes
POWER SUPPLY						
Operating Voltage	V_{CC}	2.7	3.0	3.6	VDC	–
With Dropping Resistor		4.3	5.0	5.2	VDC	1,5
Supply Current	I_{CC}	4.0	5.2	7.0	mA	–
Power-Down Current	I_{PDN}	20.0	28.0	35.0	μ A	5
RECEIVER SECTION						
Receive Frequency Range:	F_C					
RXD-315-KH2		–	315	–	MHz	–
RXD-418-KH2		–	418	–	MHz	–
RXD-433-KH2		–	433.92	–	MHz	–
Center Frequency Accuracy	–	-50	–	+50	kHz	–
LO Feedthrough	–	–	-80	–	dBm	2,5
IF Frequency	F_{IF}	–	10.7	–	MHz	5
Noise Bandwidth	N_{3dB}	–	280	–	kHz	–
Data Rate	–	100	–	10,000	bps	–
Data Output:						
Logic Low	V_{OL}	–	0.0	–	VDC	3
Logic High	V_{OH}	–	3.0	–	VDC	3
Power-Down Input:						
Logic Low	V_{IL}	–	–	0.4	VDC	–
Logic High	V_{IH}	$V_{CC}-0.4$	–	–	VDC	–
Receiver Sensitivity	–	-106	-112	-118	dBm	4
RSSI / Analog:						
Dynamic Range	–	–	80	–	dB	5
Analog Bandwidth	–	50	–	5,000	Hz	5
Gain	–	–	16	–	mV / dB	5
Voltage With No Carrier	–	–	1.5	–	V	5
ANTENNA PORT						
RF Input Impedance	R_{IN}	–	50	–	Ω	5
TIMING						
Receiver Turn-On Time:						
Via V_{CC}	–	3.0	7.0	10.0	mSec	5,6
Via PDN	–	0.04	0.25	0.50	mSec	5,6
Max. Time Between Transitions	–	–	10.0	–	mSec	5
DECODER SECTION						
TX Data Length	–	–	26 bits 3x	–	–	–
Average Data Duty Cycle	–	–	50%	–	–	–
Decoder Oscillator	F_{ENC}	–	70	–	kHz	–
Output Drive Current	–	0.6	1.0	1.2	mA	7
ENVIRONMENTAL						
Operating Temperature Range	–	-40	–	+70	$^{\circ}$ C	5

Notes

1. The KH2 can utilize a 4.3 to 5.2VDC supply provided a 330-ohm resistor is placed in series with VCC.
2. Into a 50-ohm load.
3. When operating from a 5V source, it is important to consider that the output will swing to well less than 5 volts as a result of the required dropping resistor. Please verify that the minimum voltage will meet the high threshold requirement of the device to which data is being sent.
4. For BER of 10^{-5} at 1,200bps.
5. Characterized, but not tested.
6. Time to valid data output.
7. Maximum drive capability of data outputs.



DESCRIPTION

Housed in a tiny SMD package, the ES Series offers an unmatched combination of features, performance, and cost-effectiveness. The ES utilizes an advanced FM / FSK-based synthesized architecture to provide superior performance and noise immunity when compared to AM / OOK solutions. An outstanding 56kbps maximum data rate and wide-range analog capability make the ES Series equally at home with digital data or analog sources. A host of useful features including PDN, LADJ, low voltage detect, and a microprocessor clock source are provided. The ES operates in the 900MHz (U.S.) or 868MHz (Europe) band, which allows a wide variety of applications including data links, audio links, home and industrial automation, security, remote control / command, and monitoring. As with all Linx modules, the ES Series requires no tuning or external RF components (except an antenna).

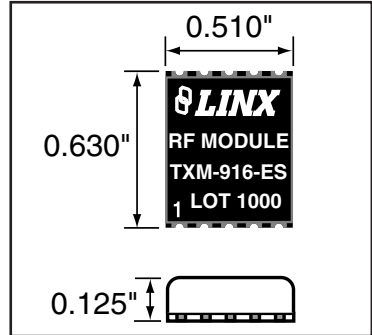

PHYSICAL DIMENSIONS

FEATURES

- Ultra-compact SMD package
- FM / FSK modulation
- Wide bandwidth (20Hz-28kHz)
- Very low current consumption
- Data rates to 56,000bps
- User power-down input
- Low-voltage detect output
- Microprocessor clock output
- No production tuning
- No external RF components required
- Precision frequency synthesized architecture
- Direct interface to analog and digital sources
- Excellent cost / performance ratio

APPLICATIONS INCLUDE

- Wireless Data Transfer
- Wireless Analog / Audio
- Home / Industrial Automation
- Keyless Entry
- Remote Control
- Fire / Security Alarms
- Wireless Networks
- Remote Status Sensing / Telemetry
- Long-Range RFID
- RS-232 / 485 Data Links
- Voice / Music Links / Intercom

ORDERING INFORMATION

PART #	DESCRIPTION
TXM-916-ES	Transmitter 916MHz
RXM-916-ES	Receiver 916MHz
TXM-869-ES	Transmitter 869MHz
RXM-869-ES	Receiver 869MHz
EVAL-***-ES	Basic Evaluation Kit
MDEV-***-ES	Master Development Kit

*** = Frequency

ES transmitters are supplied in tubes of 40 pcs.

ELECTRICAL SPECIFICATIONS

Parameter	Designation	Min.	Typical	Max.	Units	Notes
POWER SUPPLY						
Operating Voltage	V_{CC}	2.1	3.0	4.0	VDC	–
Supply Current	I_{CC}	5.5	7.0	8.5	mA	–
Power-Down Current	I_{PDN}	–	90.0	–	μ A	7
TRANSMIT SECTION						
Transmit Frequency:	F_C					
TXM-916-ES		–	916.48	–	MHz	4
TXM-869-ES		–	869.85	–	MHz	4
Center Frequency Accuracy	–	-60	–	+60	kHz	1
Output Power	P_O	-3	0	+4	dBm	2,3
Output Power Control Range	–	–	65	–	dB	2,3,7
Harmonic Emissions	P_H	–	-55	-47	dBc	2
Frequency Deviation	F_{DEV}					
TXM-916-ES	–	80	–	130	kHz	5
TXM-869-ES	–	70	–	130	kHz	5
Data Rate	–	200	–	56,000	bps	7
Analog/Audio Bandwidth	–	20	–	28,000	Hz	6,7
Data Input:						
Logic Low	V_{IL}	0.0	–	0.4	VDC	8
Logic High	V_{IH}	3.0	–	5.2	VDC	8
Power-Down Input:						
Logic Low	–	0.0	–	0.7	VDC	–
Logic High	–	1.5	–	V_{CC}	VDC	–
Analog Input	–	0.0	–	5.0	$V_{P,P}$	9
ANTENNA PORT						
RF Output Impedance	R_{OUT}	–	50	–	Ω	7
TIMING						
Transmitter Turn-On Time	–	0.1	0.5	1.5	mSec	7,10
Max. Time Between Transitions	–	–	–	5.0	mSec	7,11
ENVIRONMENTAL						
Operating Temperature Range	–	0	–	+70	$^{\circ}$ C	7

Notes

- Center frequency measured while modulated with a 0-5V square wave.
- Into a 50-ohm load.
- LADJ open.
- Maximum power when LADJ open, minimum power when LADJ grounded.
- DATA pin modulated with a 0-5V square wave.
- The audio bandwidth is wide to accommodate the needs of the data slicer.
- Characterized, but not tested.
- The ES is optimized for both 0-5V and 0-3V modulation when sending digital data.
- Analog signals, including audio, should be AC-coupled.
- Time to transmitter readiness from the application of power to V_{CC} or PDN going high.
- Maximum time without a data transition.

ABSOLUTE MAXIMUM RATINGS

Supply Voltage V_{CC}	-0.3	to	+4.0	VDC
Any Input or Output Pin	-0.5	to	$V_{CC} + 0.5$	VDC
Operating Temperature	0	to	+70	$^{\circ}$ C
Storage Temperature	-40	to	+90	$^{\circ}$ C
Soldering Temperature	+225 $^{\circ}$ C for 10 seconds			

NOTE Exceeding any of the limits of this section may lead to permanent damage to the device. Furthermore, extended operation at these maximum ratings may reduce the life of this device.

LINX[®] ES SERIES RECEIVER MODULE

TECHNOLOGIES
WIRELESS MADE SIMPLE[®]



RF MODULES 1

DESCRIPTION

Housed in a tiny SMD package, the ES Series offers an impressive combination of features, performance and cost-effectiveness. The ES utilizes an advanced synthesized FM / FSK architecture to provide superior performance and noise immunity when compared to AM / OOK solutions. An outstanding 56kbps maximum data rate and wide-range analog capability make the ES Series equally at home with digital data or analog sources such as audio. A host of useful features including RSSI, PDN, and an audio reference are provided. The ES operates in the 900MHz (U.S.) or 868MHz (Europe) band, which allows a wide variety of applications including data links, audio links, home and industrial automation, security, remote control / command, and monitoring. The ES Series requires no tuning or external RF components (except an antenna).

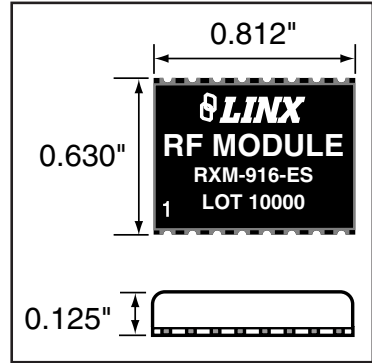

PHYSICAL DIMENSIONS

FEATURES

- Ultra-compact SMD package
- FM / FSK modulation for outstanding performance
- High noise immunity
- Precision synthesized architecture
- Excellent sensitivity
- Low current consumption
- High 56,000bps data rate
- Direct interface to analog and digital sources
- Wide-range analog capability
- No tuning or external RF components required
- RSSI and power-down lines

APPLICATIONS INCLUDE

- Wireless Data Transfer
- Wireless Analog / Audio
- Home / Industrial Automation
- Keyless Entry
- Remote Control
- Fire / Security Alarms
- Telemetry
- Remote Status Sensing
- RS-232 / 485 Data Links
- MIDI Links
- Long-Range RFID

ORDERING INFORMATION

PART #	DESCRIPTION
TXM-916-ES	Transmitter 916MHz
RXM-916-ES	Receiver 916MHz
TXM-869-ES	Transmitter 869MHz
RXM-869-ES	Receiver 869MHz
EVAL-***-ES	Basic Evaluation Kit
MDEV-***-ES	Master Development Kit
*** = Frequency	
ES receivers are supplied in tubes of 25 pcs.	

ELECTRICAL SPECIFICATIONS

Parameter	Designation	Min.	Typical	Max.	Units	Notes
POWER SUPPLY						
Operating Voltage	V_{CC}	4.5	5.0	5.5	VDC	–
Supply Current	I_{CC}	5.5	6.0	6.5	mA	–
Power-Down Current	I_{PDN}		50.0		μ A	4
RECEIVER SECTION						
Receive Frequency:	F_C					
RXM-869-ES		–	869.85	–	MHz	–
RXM-916-ES		–	916.48	–	MHz	–
Center Frequency Accuracy		–50	–	+50	kHz	–
IF Frequency	F_{IF}	–	10.7	–	MHz	–
Spurious Emissions		–	–75	–50	dBm	1
Receiver Sensitivity		–92	–97	–102	dBm	2
Noise Bandwidth	N_{3dB}	–	280	–	kHz	–
Audio Bandwidth		200	–	28,000	Hz	3,4
Audio Output Level		–	360	–	mV _{P-P}	4,5
Data Rate		200	–	56,000	bps	4
Data Output:						
Logic Low	V_{OL}	–	0.0	0.1	VDC	–
Logic High	V_{OH}	$V_{CC} - 1.1$	$V_{CC} - 1$	$V_{CC} - 0.9$	VDC	–
RSSI:						
Dynamic Range		–	60	–	dB	4
Gain		–	30	–	mV/dB	4
Voltage with No Carrier		–	1.1	–	V	4
Voltage with Max Carrier		–	2.9	–	V	4
ANTENNA PORT						
RF Input Impedance	R_{IN}	–	50	–	Ω	4
TIMING						
Receiver Turn-On Time:						
Via V_{CC}		3.8	4.7	5.4	mSec	4,6
Via PDN					mSec	4,6
Max Time Between Transitions		–	5.0	–	mSec	4,7
ENVIRONMENTAL						
Operating Temperature Range		0	–	+70	$^{\circ}$ C	4

Notes

1. Into a 50-ohm load.
2. For a 10^{-5} BER at 9,600bps.
3. The audio bandwidth is wide to accommodate the needs of the data slicer. In audio applications, audio quality may be improved by using a low-pass filter rolling off at the maximum frequency of interest.
4. Characterized, but not tested.
5. Input frequency deviation-dependent.
6. Time to receiver readiness from the application of power to V_{CC} or PDN going high.
7. Maximum time without a data transition.

ABSOLUTE MAXIMUM RATINGS

Supply Voltage V_{CC}	–0.3	to	+5.5	VDC
Any Input or Output Pin	–0.3	to	$V_{CC} + 0.3$	VDC
RF Input		+10		dBm
Operating Temperature	0	to	+70	$^{\circ}$ C
Storage Temperature	–40	to	+125	$^{\circ}$ C
Soldering Temperature	+225 $^{\circ}$ C for 10 seconds			

NOTE Exceeding any of the limits of this section may lead to permanent damage to the device. Furthermore, extended operation at these maximum ratings may reduce the life of this device.



DESCRIPTION

The HP3 RF transmitter module is the third generation of the popular HP Series and offers complete compatibility and numerous enhancements over previous generations. Like its predecessors, the HP3 is designed for the cost-effective, high-performance wireless transfer of analog or digital information in the popular 902-928MHz band. All HP3 Series parts feature eight parallel selectable channels, but versions are also available which add serial selection of 100 channels. To ensure reliable performance, the transmitter employs FM / FSK modulation and a microprocessor controlled synthesized architecture. The transmitter is pin- and footprint-compatible with all previous generations, but its overall physical size has been reduced. Both SMD and pinned packages are available. When paired with an HP3 receiver, a reliable link is created for transferring analog and digital information up to 1,000 feet. Like all Linx modules, the HP3 requires no tuning or additional RF components (except an antenna), making integration straightforward, even for engineers without prior RF experience.

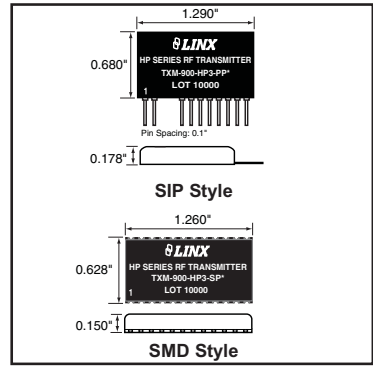

PHYSICAL DIMENSIONS

FEATURES

- 8 parallel, 100 serial (PS Versions) user-selectable channels
- Precision frequency synthesized architecture
- FM / FSK modulation for outstanding performance and noise immunity
- Transparent analog / digital interface
- Wide-range analog capability including audio (50Hz to 28kHz)
- Extended temperature range (-30°C to +85°C)
- No external RF components required
- Compatible with previous HP series modules
- Power-down and CTS functions
- Wide supply range (2.8 to 13.0VDC)
- Cost-effective
- Pinned or SMD packaging
- High data rate (up to 56kbps)
- No production tuning

APPLICATIONS INCLUDE

- Wireless Data Transfer
- Wireless Analog / Audio
- Home / Industrial Automation
- Wireless Networks
- Remote Control
- Remote Access
- Remote Monitoring / Telemetry
- Alarm / Security Systems
- Long-Range RFID
- MIDI Links
- Voice / Music / Intercom Links

ORDERING INFORMATION

PART #	DESCRIPTION
TXM-900-HP3-PPO	HP3 Transmitter (SIP 8 CH only)
TXM-900-HP3-PPS	HP3 Transmitter (SIP 8p / 100s CH)
TXM-900-HP3-SPO	HP3 Transmitter (SMD 8 CH only)
TXM-900-HP3-SPS	HP3 Transmitter (SMD 8p / 100s CH)
MDEV-900-HP3-PPS-USB	HP3 Development Kit (SIP Pkg.)
MDEV-900-HP3-PPS-RS232	HP3 Development Kit (SIP Pkg.)
MDEV-900-HP3-SPS-USB	HP3 Development Kit (SMD Pkg.)
MDEV-900-HP3-SPS-RS232	HP3 Development Kit (SMD Pkg.)

Transmitters are supplied in tubes of 15 pcs.

ELECTRICAL SPECIFICATIONS

Parameter	Designation	Min.	Typical	Max.	Units	Notes
POWER SUPPLY						
Operating Voltage	V_{CC}	2.8	3.0	13.0	VDC	–
Supply Current	I_{CC}	–	14.0	17.0	mA	1
Power-Down Current	I_{PDN}	–	–	15.0	μ A	2
TRANSMIT SECTION						
Transmit Frequency Range	F_C	902.62	–	927.62	MHz	3
Center Frequency Accuracy	–	-50	–	+50	kHz	–
Available Channels	–	8 (Par.)	–	100 (Ser.)	–	4
Channel Spacing	–	–	250	–	kHz	–
Occupied Bandwidth	–	–	115	140	kHz	–
Output Power	P_O	-3	0	+3	dBm	5
Spurious Emissions	–	–	-45	–	dBm	6
Harmonic Emissions	P_H	–	-60	-47	dBm	6
Data Rate	–	100	–	56,000	bps	7
Analog / Audio Bandwidth	–	50	–	28,000	Hz	7
Data Input:						
Logic Low	–	0.0	–	0.5	VDC	–
Logic High	–	2.8	–	5.2	VDC	–
Data Input Impedance	–	–	200	–	$k\Omega$	–
Frequency Deviation @ 3VDC	–	60	70	110	kHz	8
Frequency Deviation @ 5VDC	–	90	115	140	kHz	8
ANTENNA PORT						
RF Output Impedance	R_{OUT}	–	50	–	Ω	–
TIMING						
Transmitter Turn-On Time	–	–	7.0	10.0	mSec	–
Channel Change Time	–	–	1.0	1.5	mSec	–
ENVIRONMENTAL						
Operating Temperature Range	–	-30	–	+85	$^{\circ}$ C	–

Notes

- Over the entire operating voltage range.
- With the PDN pin low.
- Serial mode.
- 100 serial channels on the PS versions only.
- Does not change over the 3-13VDC supply.
- Into 50 ohms.
- The receiver will not reliably hold a DC level. See the receiver data guide for the min. transition rate.
- The voltage specified is the modulation pin voltage.

ABSOLUTE MAXIMUM RATINGS

Supply Voltage V_{CC}	-0.3	to	+18.0	VDC
Any Input or Output Pin	-0.3	to	V_{CC}	VDC
Operating Temperature	-30	to	+85	$^{\circ}$ C
Storage Temperature	-45	to	+85	$^{\circ}$ C
Soldering Temperature	+260 $^{\circ}$ C for 10 seconds			

NOTE Exceeding any of the limits of this section may lead to permanent damage to the device. Furthermore, extended operation at these maximum ratings may reduce the life of this device.



DESCRIPTION

The HP3 RF receiver module offers complete compatibility and numerous enhancements over previous generations. The HP3 is designed for the cost-effective, high-performance wireless transfer of analog or digital information in the popular 902-928MHz band. All HP3 Series modules feature eight parallel selectable channels, but versions are also available which add serial selection of 100 channels. To ensure reliable performance, the receiver employs FM / FSK demodulation and an advanced dual-conversion microprocessor-controlled synthesized architecture. The receiver is pin- and footprint-compatible with all previous generations, but its overall physical size has been reduced. Both SMD and pinned packages are available. When paired with an HP3 transmitter, a reliable link is created for transferring analog and digital information up to 1,000 feet. (under optimal conditions). As with all Linx modules, the HP3 requires no tuning or additional RF components (except an antenna), making integration straightforward even for engineers without prior RF experience.

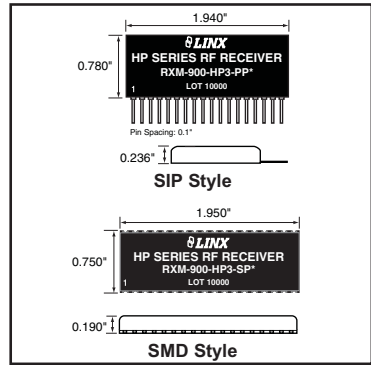

PHYSICAL DIMENSIONS

FEATURES

- 8 parallel / 100 serial (PS Versions) user-selectable channels
- Precision frequency synthesized architecture
- FM / FSK demodulation for outstanding performance and noise immunity
- Exceptional sensitivity (-100dBm typical)
- Wide-range analog capability including audio (50Hz to 28kHz)
- RSSI and Power-down lines
- No production tuning or external RF components required
- SAW filter for superior out-of-band rejection
- Compatible with previous HP Series modules
- Transparent serial data output (56kbps max.)
- Wide supply range (2.8 to 13.0VDC)
- Direct serial interface
- Cost-effective
- Pinned or SMD packaging
- Wide temperature range (-30°C to +85°C)

APPLICATIONS INCLUDE

- General Wire Elimination
- Wireless Data Transfer
- Wireless Analog / Audio
- Home / Industrial Automation
- Wireless Networks
- Remote Control
- Remote Access
- Remote Monitoring / Telemetry
- Alarm / Security Systems
- Long-Range RFID
- MIDI Links
- Voice / Music / Intercom Links

ORDERING INFORMATION

PART #	DESCRIPTION
RXM-900-HP3-PPO	HP3 Receiver (SIP 8 CH only)
RXM-900-HP3-PPS	HP3 Receiver (SIP 8p / 100s CH)
RXM-900-HP3-SPO	HP3 Receiver (SMD 8 CH only)
RXM-900-HP3-SPS	HP3 Receiver (SMD 8p / 100s CH)
MDEV-900-HP3-PPS-USB	HP3 Development Kit (Pinned Pkg.)
MDEV-900-HP3-PPS-RS232	HP3 Development Kit (Pinned Pkg.)
MDEV-900-HP3-SPS-USB	HP3 Development Kit (SMD Pkg.)
MDEV-900-HP3-SPS-RS232	HP3 Development Kit (SMD Pkg.)

Receivers are supplied in tubes of 10 pcs.

ELECTRICAL SPECIFICATIONS

Parameter	Designation	Min.	Typical	Max.	Units	Notes
POWER SUPPLY						
Operating Voltage	V_{CC}	2.8	–	13.0	VDC	–
Supply Current	I_{CC}	16.0	19.0	21.0	mA	1
Power-Down Current	I_{PDN}	–	5.5	10.0	μ A	2
RECEIVER SECTION						
Receive Frequency Range	F_C	902.62	–	927.62	MHz	4
Center Frequency Accuracy	–	-50	–	+50	kHz	–
Channel Spacing	–	–	250	–	kHz	4
First IF Frequency	–	–	34.7	–	MHz	–
Second IF Frequency	–	–	10.7	–	MHz	–
Noise Bandwidth	N_{3dB}	–	280	–	kHz	–
Data Rate	–	100	–	56,000	bps	–
Analog / Audio Bandwidth	–	50	–	28,000	Hz	–
Analog / Audio Level	–	0.8	1.1	2.0	VAC	5
Data Output:						
Logic Low	–	0.0	–	0.5	VDC	–
Logic High	–	$V_{CC}-0.3$	–	V_{CC}	VDC	–
Data Output Impedance	–	–	17	–	$k\Omega$	–
Data Output Source Current	–	–	230	–	μ A	3
Receiver Sensitivity	–	-94	-100	-107	dBm	6,7,8
RSSI:						
Dynamic Range	–	60	70	80	dB	–
Gain	–	–	24.0	–	mV/dB	–
Voltage With No Carrier	–	–	–	1.6	V	–
Spurious Emissions	–	–	-57	–	dBm	–
Interference Rejection:						
$F_C \pm 1$ MHz	–	–	54	–	dB	–
$F_C \pm 5$ MHz	–	–	57	–	dB	–
ANTENNA PORT						
RF Input Impedance	R_{IN}	–	50	–	Ω	4
TIMING						
Receiver Turn-On Time:						
Via V_{CC}	–	–	–	7	mSec	–
Via PDN	–	–	–	3	mSec	–
Max. Time Between Transitions	–	–	–	20	mSec	9
Channel Change Time	–	–	–	1.5	mSec	–
ENVIRONMENTAL						
Operating Temperature Range	–	-30	–	+85	$^{\circ}$ C	–

Notes

- Over entire operating voltage range.
- No load.
- With a 1V output drop.
- Serial mode.
- With 1kHz sine wave at 115kHz transmitter deviation.
- For a 10^{-5} BER at 9,600bps.
- At specified center frequency.
- Units are not rejected for better than maximum sensitivity.
- Minimum input power level to ensure that data output can hold a DC level.

ABSOLUTE MAXIMUM RATINGS

Supply Voltage V_{CC}	-0.3	to	+13.0	VDC
Any Input or Output Pin	-0.3	to	+13.0	VDC
RF Input		+10		dBm
Operating Temperature	-30	to	+85	$^{\circ}$ C
Storage Temperature	-45	to	+85	$^{\circ}$ C
Soldering Temperature	+260 $^{\circ}$ C for 15 seconds			

NOTE Exceeding any of the limits of this section may lead to permanent damage to the device. Furthermore, extended operation at these maximum ratings may reduce the life of this device.

LINX[®] SG SERIES GPS RECEIVER MODULE

TECHNOLOGIES
WIRELESS MADE SIMPLE[®]



RF MODULES 1

DESCRIPTION

The SG Series GPS receiver module is a self-contained high-performance GPS receiver with an on-board LNA and SAW filter. Based on the SiRFstar III chipset, it provides exceptional sensitivity, even in dense foliage and urban canyons. The module's very low power consumption helps maximize runtimes in battery powered applications. With over 200,000 effective correlators, the SG Series receiver can acquire and track up to 20 satellites simultaneously in just seconds, even at the lowest signal levels. Housed in a compact reflow-compatible SMD package, the receiver requires no programming or additional RF components (except an antenna) to form a complete GPS solution. Five GPIOs are easily configured through simple serial commands. These features, along with the module's standard NMEA data output, make the SG Series easy to integrate, even by engineers without previous RF or GPS experience.

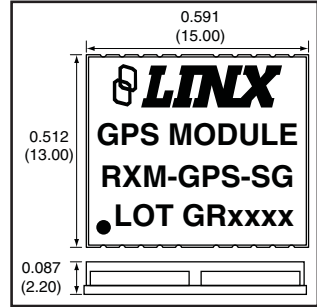

PHYSICAL DIMENSIONS

FEATURES

- SiRF Star III chipset
- 200,000+ correlators
- Low power consumption (46mW)
- High sensitivity (-159dBm)
- 20 channels
- Fast TTFF at low signal levels
- Battery-backed SRAM
- No programming necessary
- No external RF components needed (except an antenna)
- No production tuning
- Direct serial interface
- Power down feature
- Compact surface-mount package
- Manual or reflow compatible
- RoHS compliant

APPLICATIONS INCLUDE

- Positioning and Navigation
- Location and Tracking
- Security/Loss-Prevention
- Surveying
- Logistics
- Fleet Management

ORDERING INFORMATION

PART #	DESCRIPTION
RXM-GPS-SG-x	GPS Receiver Module
MDEV-GPS-SG	Master Development System
x = "T" for Tape and Reel, "B" for Bulk	
Reels are 1,000 pcs.	
Quantities less than 1,000 pcs. are supplied in bulk	

ELECTRICAL SPECIFICATIONS

Parameter	Designation	Min.	Typical	Max.	Units	Notes
POWER SUPPLY						
Supply Voltage	V_{CC}	3.0	–	4.2	VDC	1
Supply Current:	I_{CC}					2
Peak		–	–	46.0	mA	6
Acquisition		–	32	–	mA	6
Tracking		–	28	–	mA	6
Standby		–	1.5	–	mA	6
Backup Battery Voltage	V_{BAT}	1.3	–	6.0	VDC	–
Backup Battery Current	I_{BAT}	–	–	–	μ A	–
2.85V Output Voltage	V_{OUT}	2.79	2.85	2.91	VDC	–
2.85V Output Current	I_{OUT}	–	–	30	mA	3
Output Logic Low Voltage	V_{OL}	–	–	$0.25 \cdot V_{OUT}$	VDC	–
Output Logic High Voltage	V_{OH}	$0.75 \cdot V_{OUT}$	–	–	VDC	–
Output Logic Low Current	I_{OL}	–	2	–	mA	–
Output Logic High Current	I_{OH}	–	2	–	mA	–
Input Logic Low Voltage	V_{IL}	-0.3	–	$0.3 \cdot V_{OUT}$	VDC	–
Input Logic High Voltage	V_{IH}	$0.7 \cdot V_{OUT}$	–	3.6	VDC	–
Input Logic Low Current	I_{IL}	-60	–	20	μ A	–
With Pull-down		–	–	60	μ A	–
Input Logic High Current	I_{IH}	-60	–	20	μ A	–
With Pull-down		–	–	60	μ A	–
Input Capacitance	C_{IN}	–	–	4	pF	–
Output Capacitance	C_{OUT}	–	–	4	pF	4
LNA SECTION						
Insertion Power Gain	$IS_{21}I^2$	–	18	–	dB	5
Noise Figure	NF	–	0.9	–	dB	5
ANTENNA PORT						
RF Input Impedance	R_{IN}	–	50	–	Ω	–
ENVIRONMENTAL						
Operating Temperature Range	–	-30	–	+85	$^{\circ}$ C	–
Storage Temperature Range	–	-40	25	+85	$^{\circ}$ C	–
RECEIVER SECTION						
Receiver Sensitivity						
Tracking		–	-159	–	dBm	–
Cold Start		–	-144	–	dBm	–
Acquisition Time						
Hot Start (Open Sky)		–	–	2	S	–
Hot Start (Indoor)		–	–	15	S	–
Cold Start		–	35	–	S	–
Position Accuracy						
Autonomous		–	–	10	m	–
SBAS		–	–	5	m	–
Altitude		–	–	60,000	ft	–
Velocity		–	–	1,000	Knots	–
Chipset	SiRF Star III, GSC3f/LPx 7990					
Firmware Version	GSW3.5.0_3.5.00.00-SDK-3EP2.01A					
Frequency	L1 1575.42MHz, C/A Code					
Channels	20					
Update Rate	1Hz					
Protocol Support	NMEA 0183 ver 3.0, SiRF Binary					

Notes: 1. $I_{OUT} = 0$ 2. $V_{CC} = 3.3V, I_{OUT} = 0$ 3. $V_{CC} = 3.3V$ 4. Output buffer 5. At 25° C

LINX[®] SR SERIES GPS RECEIVER MODULE

TECHNOLOGIES
WIRELESS MADE SIMPLE[®]



RF MODULES 1

DESCRIPTION

The SR Series GPS receiver module is a self-contained high-performance GPS receiver with an on-board antenna, LNA and SAW filter. Based on the SiRFstar III chipset, it provides exceptional sensitivity, even in dense foliage and urban canyons. The module's very low power consumption helps maximize runtimes in battery powered applications. With over 200,000 effective correlators, the SR Series receiver can acquire and track up to 20 satellites simultaneously in just seconds, even at the lowest signal levels. Housed in a compact reflow-compatible SMD package, the receiver requires no programming or additional RF components to form a complete GPS solution. These features, along with the module's standard NMEA data output, make the SR Series easy to integrate, even by engineers without previous RF or GPS experience.

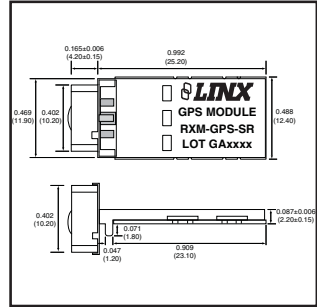

PHYSICAL DIMENSIONS

FEATURES

- SiRF Star III chipset
- 200,000+ correlators
- Low power consumption (46mW)
- High sensitivity (-159dBm)
- 20 channels
- Fast TTFF at low signal levels
- Battery-backed SRAM
- No programming necessary
- No external RF components needed
- Integral antenna
- No production tuning
- Direct serial interface
- Power down feature
- Compact surface-mount package
- Manual or reflow compatible
- RoHS compliant

APPLICATIONS INCLUDE

- Positioning and Navigation
- Location and Tracking
- Security/Loss-Prevention
- Surveying
- Logistics
- Fleet Management

ORDERING INFORMATION

PART #	DESCRIPTION
RXM-GPS-SR-x	GPS Receiver Module
MDEV-GPS-SR	Master Development System
x = "T" for Tape and Reel, "B" for Bulk	
Reels are 250 pcs.	
Quantities less than 250 pcs. are supplied in bulk	

ELECTRICAL SPECIFICATIONS

Parameter	Designation	Min.	Typical	Max.	Units	Notes
POWER SUPPLY						
Supply Voltage	V_{CC}	3.0	–	4.3	VDC	–
Supply Current:	I_{CC}					1
Peak		–	31	49	mA	–
Sleep		–	<0.1	–	mA	–
Backup Battery Voltage	V_{BAT}	1.3	–	6.0	VDC	–
Backup Battery Current	I_{BAT}	–	10	–	μ A	–
Output Logic Low Voltage	V_{OL}	–	–	0.73	VDC	–
Output Logic High Voltage	V_{OH}	2.0	–	–	VDC	–
Output Logic Low Current	I_{OL}	–	2	–	mA	–
Output Logic High Current	I_{OH}	–	2	–	mA	–
Input Logic Low Voltage	V_{IL}	-0.3	–	0.8	VDC	–
Input Logic High Voltage	V_{IH}	2.1	–	3.6	VDC	–
Input Logic Low Current	I_{IL}	-10	–	60	μ A	–
Input Logic High Current	I_{IH}	-10	–	60	μ A	–
ENABLE Logic Low Voltage	V_{IL}	–	–	0.25	VDC	–
ENABLE Logic High Voltage	V_{IH}	1.3	–	Vcc	VDC	–
ENABLE Logic Low Current	I_{IL}	-0.2	–	1	μ A	–
ENABLE Logic High Current	I_{IH}	-0.2	–	10	μ A	–
ENVIRONMENTAL						
Operating Temperature Range	–	-30	–	+85	$^{\circ}$ C	–
Storage Temperature Range	–	-40	25	+85	$^{\circ}$ C	–
RECEIVER SECTION						
Acquisition Time						
Hot Start (Open Sky)		–	–	2	S	–
Cold Start		–	35	–	S	–
Position Accuracy						
Autonomous		–	–	10	m	–
SBAS		–	–	5	m	–
Altitude		–	–	60,000	ft	–
Velocity		–	–	1,000	Knots	–
Chipset	SiRF Star III, GSC3f/LPx 7990					
Firmware Version	GSW3.5.0_3.5.00.00-SDK-3EP2.01A					
Frequency	L1 1575.42MHz, C/A Code					
Channels	20					
Update Rate	1Hz					
Protocol Support	NMEA 0183 ver 3.0, SiRF Binary					

Notes:

- $V_{CC} = 3.3V$

ABSOLUTE MAXIMUM RATINGS

Supply Voltage V_{CC}		+5.5	VDC
Input Battery Backup Voltage		+7.0	VDC
Operating Temperature	-30	to	+85 $^{\circ}$ C
Storage Temperature	-40	to	+85 $^{\circ}$ C
Soldering Temperature	+225 $^{\circ}$ C for 10 seconds		
NOTE Exceeding any of the limits of this section may lead to permanent damage to the device. Furthermore, extended operation at these maximum ratings may reduce the life of this device.			

LT SERIES BASIC EVALUATION KIT

The LT Series Basic Evaluation Kit allows the field performance of the LT Series transceiver modules to be evaluated. This kit is a cost-effective starting point and a valuable benchmark to compare the performance of your own design. The kit features pre-built evaluation boards with audible and visual indication for range and interference testing in anticipated use environments. The on-board transcoders provide bi-directional remote control with confirmation, and a prototyping area allows circuitry to be developed on the board.



Basic Kit Includes

- 2 Fully Assembled Evaluation Boards
- 4 LT Series Transceiver Modules*
- 4 CONREV SMA001 RP-SMA connectors*
- 2 CW Series Antennas
- 4 AAA Batteries
- 1 Transceiver Manual
- Part 2 + Part 15 Guidelines
- Free Technical Support

ORDERING INFORMATION	
PART #	DESCRIPTION
EVAL-315-LT	LT Basic Evaluation Kit - 315MHz
EVAL-418-LT	LT Basic Evaluation Kit - 418MHz
EVAL-433-LT	LT Basic Evaluation Kit - 433MHz

* Quantity includes those populated on the boards

LC SERIES BASIC EVALUATION KIT

This kit is a quick way to evaluate the field performance of the popular LC Series modules and verify the performance of your own design. The kit features pre-built evaluation boards with audible and visual indication for range and interference testing in anticipated use environments. It is a cost-effective starting point for your project, particularly for remote command and control applications.



Basic Kit Includes

- 2 Fully Assembled Evaluation Boards
- 2 LC Series Transmitter Modules*
- 2 LR Series Receiver Modules*
- 4 CONREVSMA001 Connectors*
- 2 CW Series Antennas
- 1 CR2032 Lithium Battery
- 2 AAA Batteries
- 1 Ea. Tx and Rx Manuals
- Part 2 + Part 15 Guidelines
- Free Technical Support

ORDERING INFORMATION	
PART #	DESCRIPTION
EVAL-315-LC	LC Basic Evaluation Kit - 315MHz
EVAL-418-LC	LC Basic Evaluation Kit - 418MHz
EVAL-433-LC	LC Basic Evaluation Kit - 433MHz

LR SERIES BASIC EVALUATION KIT

The LR Basic Evaluation Kit allows the field performance of the LR Series modules to be evaluated. This kit is a cost-effective starting point and a valuable benchmark against which to compare the performance of your own design. The kit features pre-assembled evaluation boards with audible and visual indication for range and interference testing in anticipated use environments. It is an ideal starting point for your project, particularly for remote command and control applications.



Basic Kit Includes

- 2 Fully Assembled Evaluation Boards
- 2 LR Series Transmitter Modules*
- 2 LR Series Receiver Modules*
- 4 CONREVSMA001 Connectors*
- 2 CW Series Antennas
- 1 CR2032 Lithium Battery
- 2 AAA Batteries
- 1 Ea. Tx and Rx Manuals
- Part 2 + Part 15 Guidelines
- Free Technical Support

ORDERING INFORMATION	
PART #	DESCRIPTION
EVAL-315-LR	LR Basic Evaluation Kit - 315MHz
EVAL-418-LR	LR Basic Evaluation Kit - 418MHz
EVAL-433-LR	LR Basic Evaluation Kit - 433MHz

* Quantity includes those populated on the boards

KH2 SERIES BASIC EVALUATION KIT

This kit allows rapid evaluation of the KH2 Series and serves as a valuable reference during the design process. The kit has everything needed to completely evaluate the modules, including pre-built evaluation boards, antennas, and batteries. The boards are ideal for range and interference testing. Additional modules and guidelines for integrating KH2 Series modules into your own design are also included.



Basic Kit Includes

- 2 Fully Assembled Evaluation Boards
- 2 KH2 Series TX / Encoder Modules*
- 2 KH2 Series RX / Decoder Modules*
- 4 CONREVSMA001 Connectors*
- 2 CW Series Antennas
- 1 CR2032 Lithium Battery
- 2 AAA Batteries
- 1 Ea. Tx and Rx Manuals
- Part 2 + Part 15 Guidelines
- Free Technical Support

ORDERING INFORMATION	
PART #	DESCRIPTION
EVAL-315-KH2	KH2 Basic Evaluation Kit - 315MHz
EVAL-418-KH2	KH2 Basic Evaluation Kit - 418MHz
EVAL-433-KH2	KH2 Basic Evaluation Kit - 433MHz

ES SERIES BASIC EVALUATION KIT

This kit is a quick way to evaluate the field performance of the popular ES Series modules. The kit does not allow for the level of development that our Master Kit does, but it is a cost-effective starting point for many basic applications. The development boards feature audible and visual indication for range testing and a small prototyping area with signal breakout header for the user's circuit.



Basic Kit Includes

- 2 Fully Assembled Evaluation Boards
- 2 ES Series Transmitter Modules*
- 2 ES Series Receiver Modules*
- 4 CONREVSMA001 Connectors*
- 2 CW Series Antennas
- 1 9V Battery
- 2 AAA Batteries
- 1 Ea. Tx and Rx Manuals
- Part 2 + Part 15 Guidelines
- Free Technical Support

ORDERING INFORMATION	
PART #	DESCRIPTION
EVAL-869-ES	ES Basic Evaluation Kit - 869MHz
EVAL-916-ES	ES Basic Evaluation Kit - 916MHz

* Quantity includes those populated on the boards

ES SERIES MASTER DEVELOPMENT SYSTEM

This kit provides the most complete opportunity to evaluate the Linx ES Series modules and then begin the integration of them into your own design. The kit not only allows for full evaluation of the ES modules, but also speeds the development of your own design via the included boardset, which features an onboard prototyping area, RS-232 interface, and breakout headers.



Master System Includes

- 2 Assembled Development Boards
- 2 ES Series Transmitter Modules*
- 2 ES Series Receiver Modules*
- 4 CONREVSMA001 Connectors*
- 2 CW Series Antennas
- 2 9V Batteries
- 1 Software / Documentation CD
- 2 USB Cables (USB Interface)
- Full Documentation
- Free Technical Support

* Quantity includes those populated on the boards

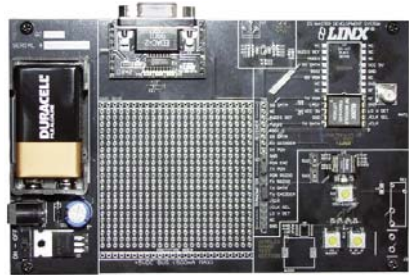

Features

- RS-232 or USB Interface
- Demonstration Software
- On-Board Encoder / Decoder ICs
- Relay Output for External Loads
- Efficient 1/4-Wave Antennas
- User Prototyping Area
- 5V On-Board Regulation
- High-Output Buzzer for Range Testing
- Pre-Assembled for Immediate Use

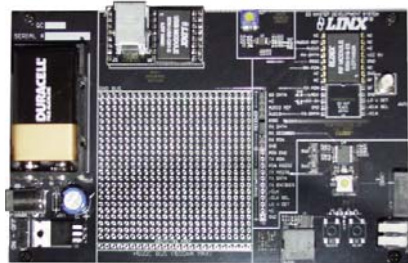

ORDERING INFORMATION

PART #	DESCRIPTION
MDEV-xxx-ES-RS232	ES Master Development System - RS-232
MDEV-xxx-ES-USB	ES Master Development System - USB
xxx = 869, 916MHz	

HP3 SERIES MASTER DEVELOPMENT SYSTEM

This kit provides a versatile platform to evaluate the Linx HP3 module family and then begin the integration of it into your own design. The kit features an on-board encoder / decoder with buzzer and relay outputs that allow range and interference testing in anticipated use environments. When you are ready to begin development, a convenient prototyping area with breakout headers and regulated power supply allows for rapid testing and interface. For applications requiring software development, RS-232 or USB host interface modules and demonstration software are provided. Finally, when you have integrated the modules into your own product, the kit will continue to serve as a valuable benchmark to compare the performance of your own layout and design.



Master System Includes

- 2 Assembled Development Boards
- 2 RS-232 or USB Interface Modules
- 2 HP3 Series Transmitter Modules*
- 2 HP3 Series Receiver Modules*
- 4 CONREVSMA001 Connectors*
- 1 Software / Documentation CD
- 2 CW Series Antennas
- 2 9V Batteries
- 2 USB Cables (USB Interface)
- Full Documentation
- Free Technical Support

Features

- On-Board Encoder / Decoder ICs
- Relay Output for External Loads
- Efficient 1/4-Wave Antennas
- RS-232 or USB Interface
- User Prototyping Area
- High-Output Buzzer for Range Testing
- 5V On-Board Regulation
- Pre-Assembled for Immediate Use

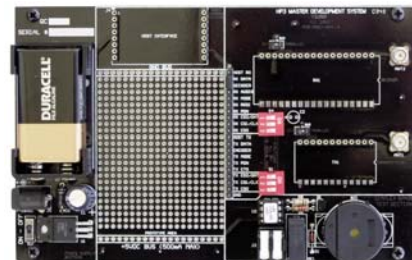
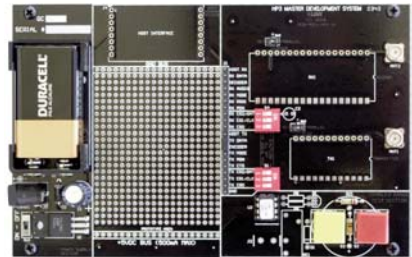

* Quantity includes those populated on the boards

ORDERING INFORMATION

PART #	DESCRIPTION
MDEV-900-HP3-xxx-RS232	HP3 Master Development System - RS-232
MDEV-900-HP3-xxx-USB	HP3 Master Development System - USB
xxx = SPS or PPS	

SG SERIES MASTER DEVELOPMENT SYSTEM

The fast track to GPS success. The Linx MDEV-GPS-SG contains everything needed to rapidly evaluate the SG Series GPS modules and implement them in record time. This all-inclusive Master Development System features a pre-assembled development board with an on-board OLED display for standalone testing. The system can also be attached to a PC via USB and operated using the supplied software. The software shows satellite positions, SNR, satellites in use, NMEA data, coordinates, and even the module's position on Google™ Maps! For development, a convenient prototyping area with breakout headers and regulated power supply allows for rapid testing and interface. Direct technical support for the system and all on-board Linx products is also included.



Master System Includes

- 2 SG Series receivers*
- 1 SH Series antenna
- 4 AAA batteries
- 1 assembled development board
- Full documentation

* Quantity includes those populated on the boards

ORDERING INFORMATION	
PART #	DESCRIPTION
MDEV-GPS-SG	SG Series Master Development System



SG SERIES MASTER DEVELOPMENT-DAUGHTERBOARD

The SG daughterboard included on the Master Development kit is also available separately for convenient use of the SG in through-hole applications.



ORDERING INFORMATION	
PART #	DESCRIPTION
ASY-MDEV-GPS-SG-DB	SG Master Dev., Daughter Board

SR SERIES MASTER DEVELOPMENT SYSTEM

The fast track to GPS success. The Linx MDEV-GPS-SR contains everything needed to rapidly evaluate the SR Series GPS modules and implement them in record time. This all-inclusive Master Development System features a pre-assembled development board with an on-board OLED display for standalone testing. The system can also be attached to a PC via USB and operated using the supplied software. The software shows satellite positions, SNR, satellites in use, NMEA data, coordinates, and even the module's position on Google™ Maps! For development, a convenient prototyping area with breakout headers and regulated power supply allows for rapid testing and interface. Direct technical support for the system and all on-board Linx products is also included.



Master System Includes

- 2 SR Series receivers*
- 4 AAA batteries
- 1 assembled development board
- Full documentation

ORDERING INFORMATION

PART #	DESCRIPTION
MDEV-GPS-SR	SR Series Master Development System

* Quantity includes those populated on the boards



SR SERIES MASTER DEVELOPMENT-DAUGHTERBOARD

The SR daughterboard included on the Master Development kit is also available separately for convenient use of the SG in through-hole applications.



ORDERING INFORMATION

PART #	DESCRIPTION
ASY-MDEV-GPS-SR-DB	SR Master Dev., Daughter Board

More Power To You



Linx offers compact, low-cost RF amplifier modules that are ideally suited to a variety of amplification and buffering applications. The broad bandwidth and gain flatness of the modules allow them to be used over a wide range of frequencies and applications, including extending the range of Linx's own RF modules (only where legally appropriate).

****IMPORTANT NOTE****

Use of these modules may result in the amplification of signals to a level that may be unacceptable for legal or technical reasons. It is the responsibility of the user to determine and adhere to the appropriate guidelines for the proposed application.

RF AMPLIFIERS

PART #	DESCRIPTION	PG.
BBA-519-A	BBA Series High Power RF Amp	44



DESCRIPTION

The BBA Series is a family of low-cost high-performance broadband RF amplifiers. The modules are ideally suited to a wide range of amplification and buffering applications, including extending the range of Linx's own RF modules (where legally appropriate). Housed in a compact SMD package, the hybrid amplifiers are matched to 50-ohm source and load impedances. The modules utilize a GaHBT gain stage, which yields high gain and IP3, excellent flatness, and low noise. The BBA-519-A is the high power model and is suitable for the final gain stage in a transmitter. This amplifier can boost the output power of a transmitter to much higher levels and provide a significant increase in range (where legally appropriate).

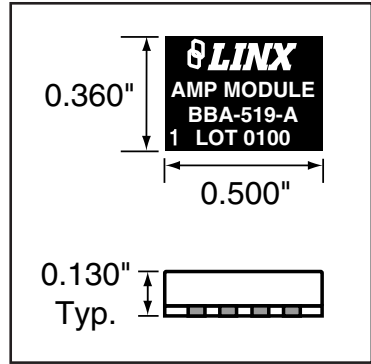

PHYSICAL DIMENSIONS

FEATURES

- Prematched for 50Ω impedance
- No external RF components required
- Exceptional gain flatness
- Compact SMD package
- High output
- 4.8dB noise figure
- 10MHz to 3GHz broadband operation
- +18dB small signal gain at 900MHz
- Up to +17dB (50mW) linear output power
- Operates from a single supply

APPLICATIONS INCLUDE

- TX / RX Range Enhancement*
- IF or RF Buffering
- Driver or Final Stage for PA
- General Purpose Gain Blocks

ORDERING INFORMATION

PART #	DESCRIPTION
BBA-519-A	High Power RF Amplifier
BBA amplifiers are supplied in tubes of 50 pcs.	

NOTE The purchaser of this device should be aware that approvals may be required by applicable governing bodies for systems producing RF energy. It is the responsibility of the user to determine and adhere to the appropriate regulations for the region in which operation is intended.

ELECTRICAL SPECIFICATIONS

Parameter	Designation	Min.	Typical	Max.	Units	Notes
POWER SUPPLY						
Operating Voltage	V_{CC}	4.8	–	5.2	VDC	2
Supply Current	I_{CC}	–	60.0	65.0	mA	–
AMPLIFIER SECTION						
Frequency Range	F_c	10	–	4,000	MHz	3
Gain:						
@ 100MHz		–	18.5	–	dB	–
@ 1,000MHz		–	17.5	–	dB	–
@ 2,000MHz		–	15.5	–	dB	–
@ 3,000MHz		–	13.5	–	dB	–
@ 4,000MHz		–	12.5	–	dB	–
Gain Ripple	–	–	±2	–	dB	4
Noise Figure	–	–	4.8	–	dB	5
Input VSWR	–	–	2.1	–	–	6
Output VSWR	–	–	1.8	–	–	6
Output IP3	–	–	+33	–	dBm	7
Output P _{1dB}	–	–	+18.5	–	dBm	8
Reverse Isolation	–	–	20	–	dB	5
ANTENNA PORT						
RF Input Impedance	R_{IN}	–	50	–	Ω	–
ENVIRONMENTAL						
Operating Temperature Range	–	0	–	+70	°C	–

Notes

1. All parameters measured at 5.0V, 25°C, -50dBm input.
2. 5.2V to 12V range is possible with the appropriate current limiting resistor.
3. T = 25°C, I_{CC} = 65mA.
4. 100MHz to 2,000MHz.
5. At 2,000MHz.
6. In a 50Ω system, DC to 4,000MHz.
7. At 1,000MHz ± 50kHz, P_{tone} = -10dBm.
8. At 1,000MHz.

ABSOLUTE MAXIMUM RATINGS

Supply Voltage V_{CC}	+4.8	to	+5.2	VDC
Supply Current			120	mA
RF Input			+13	dBm
Operating Temperature	0	to	+70	°C
Storage Temperature	-60	to	+150	°C
Soldering Temperature	+225°C for 10 seconds			

NOTE Exceeding any of the limits of this section may lead to permanent damage to the device. Furthermore, extended operation at these maximum ratings may reduce the life of this device.

Simply Connected™



Linx interface modules are designed to reliably convert data from one form to another while quickly and easily integrating into your designs. The first member of the Interface family is the QS Series USB module. The QS module makes adding a USB interface exceptionally easy by making the USB operations invisible to the user. This saves development time and costs allowing designers to bring their products to market quickly and efficiently.

INTERFACE MODULES

PART #	DESCRIPTION	PG.
SDM-USB-QS-S	QS Series USB Module	48
MDEV-USB-QS	QS Series Master Development System	50



DESCRIPTION

The Linx QS Series USB module allows the rapid addition of USB to virtually any device. Housed in a compact SMD package, the QS module provides a complete solution for converting between USB and CMOS / TTL logic level serial sources. The module can be directly connected to virtually any serial device including microprocessors, RS-232 / RS-485 level converters, or Linx wireless RF modules. The QS module is completely self contained, so it requires no external components, (except a USB jack) and includes all necessary firmware and drivers, freeing the designer from complicated programming. Power can be supplied externally or from the USB bus. Both USB 1.1 and USB 2.0 are supported at data rates up to 3Mbps.

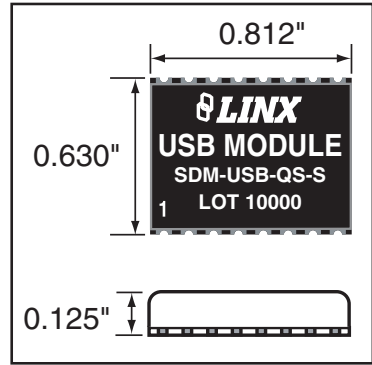

PHYSICAL DIMENSIONS

FEATURES

- Single chip conversion of USB to asynchronous serial data
- Low cost
- 3Mbps baud rate
- Supports low-speed USB
- Bus- or self-powered
- USB 1.1 and 2.0 compatible
- MS Certified Drivers included
- Compact SMD package
- VID, PID, serial number, and descriptors programmed via USB
- No external components needed (except a USB jack)
- Supports Windows 98/2000/ME/XP/Vista/Windows 7/Linux
- Full handshaking support for RS-232 and RS-485

APPLICATIONS INCLUDE

- USB to RS-232 Converters
- USB to RS-485 Converters
- Interfacing Microcontrollers to USB
- Interfacing RF Modules to USB
- USB Modems
- USB Instrumentation
- USB to Serial Converter Cables
- Upgrading Legacy Peripherals
- USB Smart Card Readers
- USB Game Controllers
- Robotics

ORDERING INFORMATION

PART #	DESCRIPTION
SDM-USB-QS-S	USB Module
MDEV-USB-QS	USB Master Development Kit

QS modules are supplied in tubes of 25 pcs.

ELECTRICAL SPECIFICATIONS

Parameter	Designation	Min.	Typical	Max.	Units	Notes
POWER SUPPLY						
Operating Voltage	V_{CC}	4.4	5.0	5.3	VDC	–
Supply Current	I_{CC}	–	26.0	28.0	mA	–
UART SECTION						
Data Rate	–	–	–	3	Mbps	–
Data Output:						
Logic Low	V_{OL}	0.1	–	0.7	VDC	–
Logic High	V_{OH}	4.4	–	5.0	VDC	–
EEPROM Size	–	–	–	1,024	Bits	–
USB SECTION						
Data Output:						
Logic Low	UV_{OL}	0.0	–	0.3	VDC	–
Logic High	UV_{OH}	2.8	–	3.6	VDC	–
Single-Ended RX Threshold	–	0.8	–	2.0	VDC	–
Differential Common Mode	–	0.8	–	2.5	VDC	–
Differential Input Sensitivity	–	0.2	–	–	VDC	–
ENVIRONMENTAL						
Operating Temperature Range	–	0	–	+70	°C	–

ABSOLUTE MAXIMUM RATINGS

Supply Voltage V_{CC}	-0.5	to	+6.0	VDC
Any Input or Output Pin	-0.5	to	$V_{CC} + 0.5$	VDC
Max Current Sourced By Data Pins			2	mA
Max Current Sunk By Data Pins			4	mA
Operating Temperature	0	to	+70	°C
Storage Temperature	-65	to	+150	°C
Soldering Temperature	+225°C for 10 seconds			

NOTE Exceeding any of the limits of this section may lead to permanent damage to the device. Furthermore, extended operation at these maximum ratings may reduce the life of this device.

SOFTWARE CONSIDERATIONS

The PC needs a set of drivers that tell it how to communicate with the QS module. The CDM drivers for the QS Series module actually install two different drivers at the same time. The first driver makes the QS appear as an extra COM port on the host PC. This allows the application to use standard writes and reads to a serial port, and the drivers will redirect data to the USB device.

The second driver supports a series of functions that allow more direct control of the QS module. These functions are described in Application Note AN-00200: SDM-USB-QS-S Programmer's Guide, where examples are given in both Visual Basic and C. The Programmer's Guide can be downloaded from the Application Notes page in the Support section of the Linx website at www.linxtechnologies.com. Sample software is available on the Software page in the Support section.

In addition to the Programmer's Guide, the QS Master Development System (MDEV-USB-QS) includes example software and sample system source code. This source code provides the driver function declarations, examples of how to use the functions in a program, and other code that may be of use.

QS SERIES MASTER DEVELOPMENT SYSTEM

This system offers the most complete way to evaluate the QS Series and then begin the integration of it into your own design. The kit allows for full evaluation of the QS modules and speeds the development of your own design via the included development board. The board demonstrates interfacing to microcontrollers and RS-232 devices. A large prototyping area with a break-out header allows for quick and easy prototyping of your device on the development board itself. Drivers and software are included as well as source code and system examples which will speed software development and system integration.



Master System Includes

- 1 Assembled Development Board
- 2 QS USB Modules*
- 1 Software / Support CD
- 1 USB Cable
- Full Documentation
- Free Technical Support

* Quantity includes those populated on the boards

Features

- Serial <--> USB Interface
- Integrated RS-232 Level Converter
- On-Board Demo Microcontroller
- User Prototyping Area
- Pre-Assembled for Immediate Use
- Demonstration Software Included
- Sample Source Code Included

ORDERING INFORMATION	
PART #	DESCRIPTION
MDEV-USB-QS	QS Master Development System

Integrated Solutions



In addition to our modular RF products, Linx offers a wide range of ICs designed to simplify such diverse tasks as encoding and decoding, interface, and discreet RF implementations.

INTEGRATED CIRCUITS

PART #	DESCRIPTION	PG.
LICAL-ENC-LS001	LS Series Encoder IC	54
LICAL-DEC-LS001	LS Series Decoder IC	54
LICAL-ENC-MS001	MS Series Encoder IC	56
LICAL-DEC-MS001	MS Series Decoder IC	58
LICAL-ENC-HS001	HS Series Encoder IC	60
LICAL-DEC-HS001	HS Series Decoder IC	62
LICAL-TRC-MT	MT Series Transcoder IC	64
MDEV-LICAL-MS	MS Master Development System w/ LR Series	66
MDEV-LICAL-MS-ES	MS Master Development System w/ ES Series	66
MDEV-LICAL-HS	HS Master Development System w/ LR Series	67
MDEV-LICAL-HS-ES	HS Master Development System w/ ES Series	67
MDEV-LICAL-MT	MT Master Development System w/ LT Series	68



DESCRIPTION

The Linx LS Series encoders and decoders provide a simple, but reliable, protocol for the transmission of switch closures or button contacts. This series can find use in any basic, low-cost remote control application. Simply take a data line high on the encoder and a corresponding line high on the decoder. No programming or addressing is required, making integration of the LS extremely easy while maintaining a robust link.

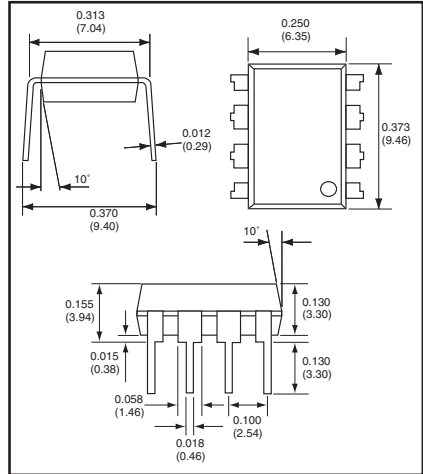

PHYSICAL DIMENSIONS

FEATURES

- No addressing or programming
- Easy to use
- Very low current consumption
- Four data lines
- Easy serial interface
- Selectable baud rates
- High noise immunity
- Standard PDIP package

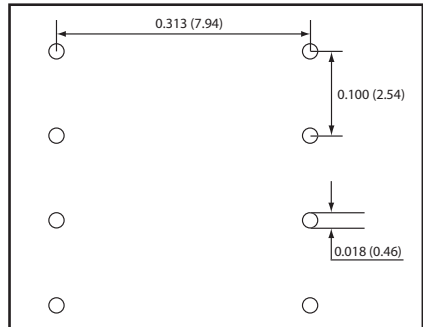

PCB LAYOUT

APPLICATIONS INCLUDE

- Range Testing
- Simple Remote Control
- Wire Elimination
- Remote Status Monitoring
- Lighting Control

ORDERING INFORMATION

PART #	DESCRIPTION
LICAL-ENC-LS001	LS Encoder
LICAL-DEC-LS001	LS Decoder

ELECTRICAL SPECIFICATIONS

Parameter	Designation	Min.	Typical	Max.	Units	Notes
POWER SUPPLY						
Operating Voltage	V_{CC}	2.0	–	5.5	VDC	–
Supply Current:	I_{CC}					
At 2.0V V_{CC}		–	340	450	μ A	1
At 3.0V V_{CC}		–	500	700	μ A	1
At 5.0V V_{CC}		–	800	1,100	μ A	1
Power-Down Current:	I_{PDN}					
At 2.0V V_{CC}		–	0.99	700	nA	
At 3.0V V_{CC}		–	1.2	770	nA	
At 5.0V V_{CC}		–	2.9	995	nA	
ENCODER / DECODER SECTION						
Input Low	V_{IL}	0.0	–	$0.15 \times V_{CC}$	V	2
Input High	V_{IH}	$0.8 \times V_{CC}$	–	V_{CC}	V	3
Output Low	V_{OL}	–	–	0.6	V	
Output High	V_{OH}	$V_{CC} - 0.7$	–	–	V	
Input Sink Current	–	–	–	25	mA	
Output Drive Current	–	–	–	25	mA	
ENVIRONMENTAL						
Operating Temperature Range	–	-40	–	+85	$^{\circ}$ C	

Notes

1. Current consumption with no active loads.
2. For 3V supply, $(0.15 \times 3.0) = 0.45V$ max.
3. For 3V supply, $(0.8 \times 3.0) = 2.4V$ min.

ABSOLUTE MAXIMUM RATINGS

Supply Voltage V_{CC}	-0.3	to	+6.5	VDC
Any Input or Output Pin	-0.3	to	$V_{CC} + 0.3$	VDC
Max. Current Sourced By Data Pins			25	mA
Max. Current Sunk By Data Pins			25	mA
Max. Current Into V_{CC}			250	mA
Max. Current Out Of GND			300	mA
Operating Temperature	-40	to	+85	$^{\circ}$ C
Storage Temperature	-65	to	+150	$^{\circ}$ C

NOTE Exceeding any of the limits of this section may lead to permanent damage to the device. Furthermore, extended operation at these maximum ratings may reduce the life of this device.



DESCRIPTION

MS Series encoders and decoders are designed for remote control applications. They allow the status of up to eight buttons or contacts to be securely transferred via a wireless link. The large, twenty-four bit address size makes transmissions highly unique, minimizing the possibility of multiple devices having conflicting addresses. The MS Series decoder allows the recognition of individual output lines to be easily defined for each transmitter by the manufacturer or the user. This enables the creation of unique user groups and relationships. The decoder also identifies and outputs the originating encoder ID for logging or identification. Housed in a tiny 20-pin SSOP package, MS Series encoders feature low supply voltage and current consumption. Selectable baud rates and latched or momentary outputs make the MS Series truly versatile.

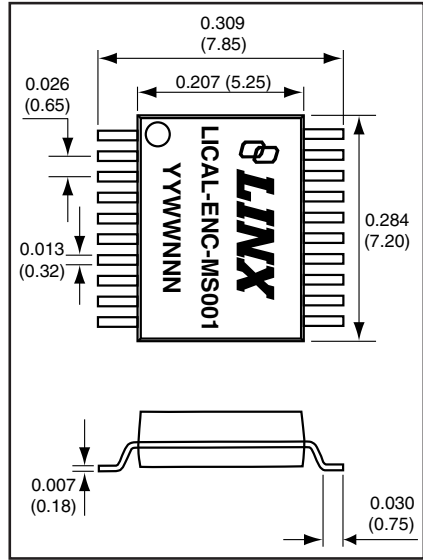

PHYSICAL DIMENSIONS

FEATURES

- Secure 2²⁴ possible addresses
- 8 data lines
- Low 2.0-5.5V operating voltage
- Low supply current (370µA @ 3V)
- Ultra-low 0.1µA standby current
- Definable recognition authority
- True serial encoding
- Excellent noise immunity
- Selectable baud rates
- No programmer required
- Direct serial interface
- Small SMD package
- Latched or momentary outputs
- Encoder ID output by decoder

APPLICATIONS INCLUDE

- Keyless Entry
- Door and Gate Openers
- Security Systems
- Remote Device Control
- Car Alarms / Starters
- Home / Industrial Automation
- Remote Status Monitoring
- Lighting Control
- Call / Paging Systems

ORDERING INFORMATION

PART #	DESCRIPTION
LICAL-ENC-MS001	MS Encoder
LICAL-DEC-MS001	MS Decoder
MDEV-LICAL-MS	MS Master Development System

MS encoders are shipped in reels of 1,600
Quantities less than reel size are supplied in bulk.

ELECTRICAL SPECIFICATIONS

Parameter	Designation	Min.	Typical	Max.	Units	Notes
POWER SUPPLY						
Operating Voltage	V_{CC}	2.0	–	5.5	VDC	–
Supply Current:	I_{CC}					
At 2.0V V_{CC}		–	240	300	μ A	1
At 3.0V V_{CC}		–	370	470	μ A	1
At 5.0V V_{CC}		–	670	780	μ A	1
Power-Down Current:	I_{PDM}					
At 2.0V V_{CC}		–	0.10	0.80	μ A	–
At 3.0V V_{CC}		–	0.10	0.85	μ A	–
At 5.0V V_{CC}		–	0.20	0.95	μ A	–
ENCODER SECTION						
Input Low	V_{IL}	0.0	–	$0.15 \times V_{CC}$	V	2
Input High	V_{IH}	$0.8 \times V_{CC}$	–	V_{CC}	V	3
Output Low	V_{OL}	–	–	0.6	V	–
Output High	V_{OH}	$V_{CC} - 0.7$	–	–	V	–
Input Sink Current	–	–	–	25	mA	–
Output Drive Current	–	–	–	25	mA	–
SEND High to DATA_OUT	–	–	1.64	–	mS	–
ENVIRONMENTAL						
Operating Temperature Range	–	–40	–	+85	$^{\circ}$ C	–

Notes

1. Current consumption with no active loads.
2. For 3V supply, $(0.15 \times 3.0) = 0.45V$ max.
3. For 3V supply, $(0.8 \times 3.0) = 2.4V$ min.

ABSOLUTE MAXIMUM RATINGS

Supply Voltage V_{CC}	–0.3	to	+6.5	VDC
Any Input or Output Pin	–0.3	to	$V_{CC} + 0.3$	VDC
Max. Current Sourced By Output Pins			25	mA
Max. Current Sunk By Output Pins			25	mA
Max. Current Into V_{CC}			250	mA
Max. Current Out Of GND			300	mA
Operating Temperature	–40	to	+85	$^{\circ}$ C
Storage Temperature	–65	to	+150	$^{\circ}$ C

NOTE Exceeding any of the limits of this section may lead to permanent damage to the device. Furthermore, extended operation at these maximum ratings may reduce the life of this device.



CAUTION

This product is a static-sensitive component. Always wear an ESD wrist strap and observe proper ESD handling procedures when working with this device. Failure to observe this precaution may result in device damage or failure.



DESCRIPTION

MS Series encoders and decoders are designed for remote control applications. They allow the status of up to eight buttons or contacts to be securely transferred via a wireless link. The large, twenty-four bit address size makes transmissions highly unique, minimizing the possibility of multiple devices having conflicting addresses. The MS Series decoder allows the recognition of individual output lines to be easily defined for each transmitter by the manufacturer or the user. This enables the creation of unique user groups and relationships. The decoder also identifies and outputs the originating encoder ID for logging or identification. Housed in a tiny 20-pin SSOP package, MS Series parts feature low supply voltage and current consumption. Selectable baud rates and latched or momentary outputs make the MS Series truly versatile.

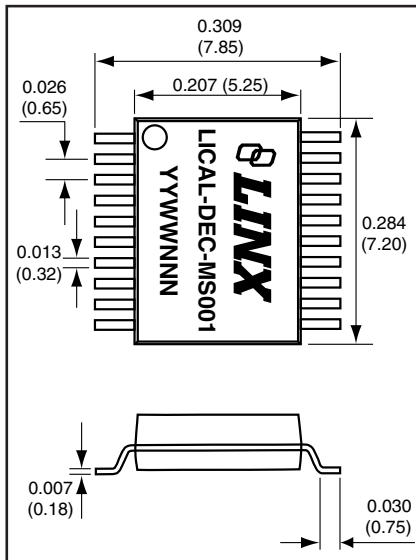

PHYSICAL DIMENSIONS

FEATURES

- Secure 2²⁴ possible addresses
- 8 data lines
- Direct serial interface
- Latched or momentary outputs
- Definable recognition authority
- Encoder ID output by decoder
- Low 2.0-5.5V operating voltage
- Low supply current (370µA @ 3V)
- Ultra-low 0.1µA standby current
- True serial encoding
- Excellent noise immunity
- Selectable baud rates
- No programming required
- Small SMD package

APPLICATIONS INCLUDE

- Keyless Entry
- Door and Gate Openers
- Security Systems
- Remote Device Control
- Car Alarms / Starters
- Home / Industrial Automation
- Remote Status Monitoring
- Lighting Control
- Call / Paging Systems

ORDERING INFORMATION

PART #	DESCRIPTION
LICAL-ENC-MS001	MS Encoder
LICAL-DEC-MS001	MS Decoder
MDEV-LICAL-MS	MS Master Development System

MS decoders are shipped in reels of 1,600

Quantities less than reel size are supplied in bulk.

ELECTRICAL SPECIFICATIONS

Parameter	Designation	Min.	Typical	Max.	Units	Notes
POWER SUPPLY						
Operating Voltage	V_{CC}	2.0	–	5.5	VDC	–
Supply Current:	I_{CC}					
At 2.0V V_{CC}		–	240	300	μ A	1
At 3.0V V_{CC}		–	370	470	μ A	1
At 5.0V V_{CC}		–	670	780	μ A	1
Power-Down Current:	I_{PDM}					
At 2.0V V_{CC}		–	0.10	0.80	μ A	–
At 3.0V V_{CC}		–	0.10	0.85	μ A	–
At 5.0V V_{CC}		–	0.20	0.95	μ A	–
ENCODER SECTION						
Input Low	V_{IL}	0.0	–	$0.15 \times V_{CC}$	V	2
Input High	V_{IH}	$0.8 \times V_{CC}$	–	V_{CC}	V	3
Output Low	V_{OL}	–	–	0.6	V	–
Output High	V_{OH}	$V_{CC} - 0.7$	–	–	V	–
Input Sink Current	–	–	–	25	mA	–
Output Drive Current	–	–	–	25	mA	–
SEND High to DATA_OUT	–	–	1.64	–	mS	–
ENVIRONMENTAL						
Operating Temperature Range	–	-40	–	+85	$^{\circ}$ C	–

Notes

1. Current consumption with no active loads.
2. For 3V supply, $(0.15 \times 3.0) = 0.45V$ max.
3. For 3V supply, $(0.8 \times 3.0) = 2.4V$ min.

ABSOLUTE MAXIMUM RATINGS

Supply Voltage V_{CC}	-0.3	to	+6.5	VDC
Any Input or Output Pin	-0.3	to	$V_{CC} + 0.3$	VDC
Max. Current Sourced By Output Pins			25	mA
Max. Current Sunk By Output Pins			25	mA
Max. Current Into V_{CC}			250	mA
Max. Current Out Of GND			300	mA
Operating Temperature	-40	to	+85	$^{\circ}$ C
Storage Temperature	-65	to	+150	$^{\circ}$ C

NOTE Exceeding any of the limits of this section may lead to permanent damage to the device. Furthermore, extended operation at these maximum ratings may reduce the life of this device.



CAUTION

This product is a static-sensitive component. Always wear an ESD wrist strap and observe proper ESD handling procedures when working with this device. Failure to observe this precaution may result in device damage or failure.



DESCRIPTION

HS Series encoders and decoders are designed for maximum security remote control applications. The HS encoder encodes the status of up to eight buttons or contacts into a highly secure encrypted output intended for wireless transmission via a RF or infrared link. The HS Series uses CipherLinx[®] technology, which is based on the Skipjack algorithm developed by the U.S. National Security Agency (NSA) and has been independently evaluated by ISE. CipherLinx[®] never sends or accepts the same data twice, never loses sync, and changes codes on every packet, not just every button press. In addition to state-of-the-art security, the tiny 20-pin SSOP packaged parts also offer innovative features, including up to 8 data lines, multiple baud rates, individual “button level” permissions, keypad user PIN, encoder identity output, low power consumption, and easy setup.

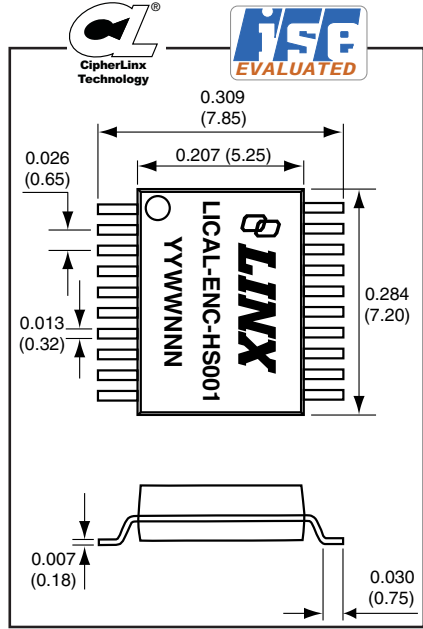

PHYSICAL DIMENSIONS

FEATURES

- CipherLinx[®] security technology
- ISE evaluated
- Never sends the same packet twice
- Never loses sync
- PIN-protected encoder access
- 8 selectable data lines
- “Button level” permissions
- Encoder ID available at decoder
- Wide 2.0 to 5.5V operating voltage
- Low supply current (370µA @ 3V)
- Ultra-low 0.1µA sleep current
- Selectable baud rates
- No programmer required
- Small SMD package

APPLICATIONS INCLUDE

- Keyless Entry / Access Control
- Door and Gate Openers
- Security Systems
- Remote Device Control
- Car Alarms / Starters
- Home / Industrial Automation
- Remote Status Monitoring

ORDERING INFORMATION

PART #	DESCRIPTION
LICAL-ENC-HS001	HS Encoder
LICAL-DEC-HS001	HS Decoder
MDEV-LICAL-HS	HS Master Development System

HS encoders are shipped in reels of 1,600

Quantities less than reel size are supplied in bulk.

ELECTRICAL SPECIFICATIONS

Parameter	Designation	Min.	Typical	Max.	Units	Notes
POWER SUPPLY						
Operating Voltage	V_{CC}	2.0	–	5.5	VDC	–
Supply Current:	I_{CC}					
At 2.0V V_{CC}		–	240	300	μ A	1
At 3.0V V_{CC}		–	370	470	μ A	1
At 5.0V V_{CC}		–	670	780	μ A	1
Power-Down Current:	I_{PDM}					
At 2.0V V_{CC}		–	0.10	0.80	μ A	–
At 3.0V V_{CC}		–	0.10	0.85	μ A	–
At 5.0V V_{CC}		–	0.20	0.95	μ A	–
ENCODER SECTION						
Input Low	V_{IL}	0.0	–	$0.15 \times V_{CC}$	V	2
Input High	V_{IH}	$0.8 \times V_{CC}$	–	V_{CC}	V	3
Output Low	V_{OL}	–	–	0.6	V	–
Output High	V_{OH}	$V_{CC} - 0.7$	–	–	V	–
Input Sink Current	–	–	–	25	mA	–
Output Drive Current	–	–	–	25	mA	–
SEND High to DATA_OUT	–	–	1.64	–	mS	–
ENVIRONMENTAL						
Operating Temperature Range	–	-40	–	+85	$^{\circ}$ C	–

Notes

1. Current consumption with no active loads.
2. For 3V supply, $(0.15 \times 3.0) = 0.45V$ max.
3. For 3V supply, $(0.8 \times 3.0) = 2.4V$ min.

ABSOLUTE MAXIMUM RATINGS

Supply Voltage V_{CC}	-0.3	to	+6.5	VDC
Any Input or Output Pin	-0.3	to	$V_{CC} + 0.3$	VDC
Max. Current Sourced By Output Pins			25	mA
Max. Current Sunk By Output Pins			25	mA
Max. Current Into V_{CC}			250	mA
Max. Current Out Of GND			300	mA
Operating Temperature	-40	to	+85	$^{\circ}$ C
Storage Temperature	-65	to	+150	$^{\circ}$ C

NOTE Exceeding any of the limits of this section may lead to permanent damage to the device. Furthermore, extended operation at these maximum ratings may reduce the life of this device.



CAUTION

This product is a static-sensitive component. Always wear an ESD wrist strap and observe proper ESD handling procedures when working with this device. Failure to observe this precaution may result in device damage or failure.



DESCRIPTION

HS Series encoders and decoders are designed for maximum security remote control applications. The HS encoder encodes the status of up to eight buttons or contacts into a highly secure encrypted output intended for wireless transmission via a RF or infrared link. The HS Series uses CipherLin^x[®] technology, which is based on the Skipjack algorithm developed by the U.S. National Security Agency (NSA) and has been independently evaluated by ISE. CipherLin^x[®] never sends or accepts the same data twice, never loses sync, and changes codes on every packet, not just every button press. In addition to state-of-the-art security, the tiny 20-pin SSOP packaged parts also offer innovative features, including up to 8 data lines, multiple baud rates, individual “button level” permissions, keypad user PIN, encoder identity output, low power consumption, and easy setup.

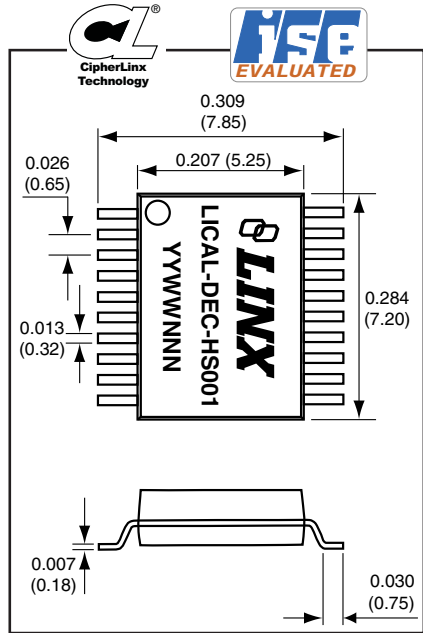

PHYSICAL DIMENSIONS

FEATURES

- CipherLin^x[®] security technology
- ISE evaluated
- Never sends the same packet twice
- Never loses sync
- PIN-protected encoder access
- 8 selectable data lines
- “Button level” permissions
- Encoder ID available at decoder
- Wide 2.0 to 5.5V operating voltage
- Low supply current (370µA @ 3V)
- Ultra-low 0.1µA sleep current
- Selectable baud rates
- No programmer required
- Small SMD package

APPLICATIONS INCLUDE

- Keyless Entry / Access Control
- Door and Gate Openers
- Security Systems
- Remote Device Control
- Car Alarms / Starters
- Home / Industrial Automation
- Remote Status Monitoring

ORDERING INFORMATION

PART #	DESCRIPTION
LICAL-ENC-HS001	HS Encoder
LICAL-DEC-HS001	HS Decoder
MDEV-LICAL-HS	HS Master Development System
HS decoders are shipped in reels of 1,600	
Quantities less than reel size are supplied in bulk.	

ELECTRICAL SPECIFICATIONS

Parameter	Designation	Min.	Typical	Max.	Units	Notes
POWER SUPPLY						
Operating Voltage	V_{CC}	2.0	–	5.5	VDC	–
Supply Current:	I_{CC}					
At 2.0V V_{CC}		–	240	300	μA	1
At 3.0V V_{CC}		–	370	470	μA	1
At 5.0V V_{CC}		–	670	780	μA	1
Power-Down Current:	I_{PDM}					
At 2.0V V_{CC}		–	0.10	0.80	μA	–
At 3.0V V_{CC}		–	0.10	0.85	μA	–
At 5.0V V_{CC}		–	0.20	0.95	μA	–
ENCODER SECTION						
Input Low	V_{IL}	0.0	–	$0.15 \times V_{CC}$	V	2
Input High	V_{IH}	$0.8 \times V_{CC}$	–	V_{CC}	V	3
Output Low	V_{OL}	–	–	0.6	V	–
Output High	V_{OH}	$V_{CC} - 0.7$	–	–	V	–
Input Sink Current	–	–	–	25	mA	–
Output Drive Current	–	–	–	25	mA	–
SEND High to DATA_OUT	–	–	1.64	–	mS	–
ENVIRONMENTAL						
Operating Temperature Range	–	-40	–	+85	$^{\circ}C$	–

Notes

1. Current consumption with no active loads.
2. For 3V supply, $(0.15 \times 3.0) = 0.45V$ max.
3. For 3V supply, $(0.8 \times 3.0) = 2.4V$ min.

ABSOLUTE MAXIMUM RATINGS

Supply Voltage V_{CC}	-0.3	to	+6.5	VDC
Any Input or Output Pin	-0.3	to	$V_{CC} + 0.3$	VDC
Max. Current Sourced By Output Pins			25	mA
Max. Current Sunk By Output Pins			25	mA
Max. Current Into V_{CC}			250	mA
Max. Current Out Of GND			300	mA
Operating Temperature	-40	to	+85	$^{\circ}C$
Storage Temperature	-65	to	+150	$^{\circ}C$

NOTE Exceeding any of the limits of this section may lead to permanent damage to the device. Furthermore, extended operation at these maximum ratings may reduce the life of this device.



CAUTION

This product is a static-sensitive component. Always wear an ESD wrist strap and observe proper ESD handling procedures when working with this device. Failure to observe this precaution may result in device damage or failure.



DESCRIPTION

MT Series transcoders are designed for bi-directional remote control applications. Eight status lines can be set up in any combination of inputs and outputs for the transfer of button or contact states. An automatic confirmation indicates that the transmission was successfully received. The large, twenty-four bit address size makes transmissions highly unique, minimizing the possibility of conflict between multiple devices. The MT also outputs the ID of the originating transcoder for logging or identification. Recognition of the individual outputs can be easily defined for each device by the manufacturer or end user. This allows the creation of user groups and relationships. A Serial Interface Engine (SIE) is provided, which allows configuration and editing of the device and control of the transcoder by an external microprocessor or PC. Housed in a tiny 20-pin SSOP package, MT Series parts feature low supply voltage, current consumption, and selectable baud rates.

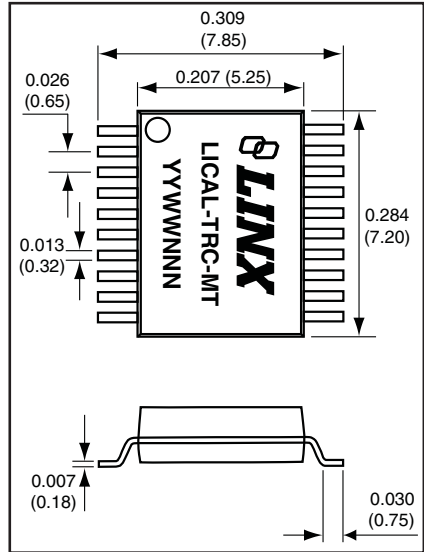

PHYSICAL DIMENSIONS

parts feature low supply voltage, current consumption, and selectable baud rates.

FEATURES

- Bi-directional control
- Automatic confirmation
- Secure 2²⁴ possible addresses
- 8 status lines
- Serial Interface Engine (SIE)
- Latched and/or momentary outputs
- Definable recognition authority
- Transmitter ID output
- Custom data transfer
- Device targeting
- Wide 2.0 to 5.5V operating voltage
- Low supply current (370µA @ 3V)
- True serial encoding
- Selectable baud rates
- No programming required

APPLICATIONS INCLUDE

- Keyless Entry
- Door and Gate Openers
- Security Systems
- Remote Device Control
- Car Alarms / Starters
- Home / Industrial Automation
- Remote Status Monitoring
- Paging

ORDERING INFORMATION

PART #	DESCRIPTION
LICAL-TRC-MT	MT Transcoder
MDEV-LICAL-MT	MT Master Development System

MT transcoders are shipped in reels of 1,600
Quantities less than reel size are supplied in bulk.

ELECTRICAL SPECIFICATIONS

Parameter	Designation	Min.	Typical	Max.	Units	Notes
POWER SUPPLY						
Operating Voltage	V_{CC}	2.0	–	5.5	VDC	–
Supply Current:	I_{CC}					
At 2.0V V_{CC}		–	340	450	μ A	1
At 3.0V V_{CC}		–	500	700	μ A	1
At 5.0V V_{CC}		–	800	1,200	μ A	1
Power-Down Current:	I_{PDM}					
At 2.0V V_{CC}		–	1.0	2.2	μ A	–
At 3.0V V_{CC}		–	2.0	4.0	μ A	–
At 5.0V V_{CC}		–	3.0	7.0	μ A	–
TRANSCODER SECTION						
Input Low	V_{IL}	0.0	–	$0.2 \times V_{CC}$	V	2
Input High	V_{IH}	$0.8 \times V_{CC}$	–	V_{CC}	V	3
Output Low	V_{OL}	–	–	0.6	V	–
Output High	V_{OH}	$V_{CC} - 0.7$	–	–	V	–
Input Sink Current	–	–	–	25	mA	–
Output Drive Current	–	–	–	25	mA	–
ENVIRONMENTAL						
Operating Temperature Range	–	-40	–	+85	$^{\circ}$ C	–

Notes

1. Current consumption with no active loads.
2. For 3V supply, $(0.2 \times 3.0) = 0.6V$ max.
3. For 3V supply, $(0.8 \times 3.0) = 2.4V$ min.

ABSOLUTE MAXIMUM RATINGS

Supply Voltage V_{CC}	-0.3	to	+6.5	VDC
Any Input or Output Pin	-0.3	to	$V_{CC} + 0.3$	VDC
Max. Current Sourced By Output Pins			25	mA
Max. Current Sunk By Output Pins			25	mA
Max. Current Into V_{CC}			250	mA
Max. Current Out Of GND			300	mA
Operating Temperature	-40	to	+85	$^{\circ}$ C
Storage Temperature	-65	to	+150	$^{\circ}$ C

NOTE Exceeding any of the limits of this section may lead to permanent damage to the device. Furthermore, extended operation at these maximum ratings may reduce the life of this device.



CAUTION

This product is a static-sensitive component. Always wear an ESD wrist strap and observe proper ESD handling procedures when working with this device. Failure to observe this precaution may result in device damage or failure.

MS SERIES MASTER DEVELOPMENT SYSTEM

INTEGRATED CIRCUITS 5

This comprehensive development system is designed to assist in the rapid evaluation and integration of MS Series encoders and decoders. The all-inclusive kit features pre-assembled evaluation boards, which have everything needed to quickly test the operation of the encoder and decoder. On-board Linx RF modules provide a wireless link for basic remote control operation. LR Series RF modules are standard, but ES Series modules can be substituted by special order. When you are ready to begin development, a convenient prototyping area with breakout headers and regulated power supply allows for rapid testing and interface. In addition to its stand-alone functions, the board can also be connected to a PC via a USB connection. Demonstration software is included which audibly and visually demonstrates the powerful capabilities of the MS Series. Technical support for the kit and all on-board Linx products is included.



Master System Includes

- 2 MS Series Encoders*
- 2 MS Series Decoders*
- 1 LR or ES Series Transmitter*
- 1 LR or ES Series Receiver*
- 2 CW Series Antennas
- 2 Assembled Evaluation Boards
- 2 9V Batteries
- 1 Software / Documentation CD
- 1 USB Cable
- Full Documentation
- Free Technical Support

* Quantity includes those populated on the boards

Features

- On-Board RF Modules
- Easy Access to All Encoder, Decoder, and RF Module lines
- Efficient 1/4-Wave Antennas
- USB Interface
- User Prototyping Area
- 3V On-Board Regulation
- Assembled for Immediate Use

ORDERING INFORMATION

PART #	DESCRIPTION
MDEV-LICAL-MS	MS Series Master Development System w/ LR Series
MDEV-LICAL-MS-ES	MS Series Master Development System w/ ES Series

HS SERIES MASTER DEVELOPMENT SYSTEM

This all-inclusive development system contains all of the tools necessary to fully explore the capabilities of Linx HS Series encoders and decoders, and assist in the rapid evaluation and integration of the parts into an end product. It features pre-assembled evaluation boards, which include everything needed to quickly test the operation of the encoder and decoder. On-board Linx RF modules provide a wireless link for basic remote control operation, which allow the encoder and decoder to be tested in a wireless environment. When you are ready to begin development, a large prototyping area with breakout headers and regulated power supply allows for rapid testing and integration of your own design. In addition to its stand-alone functions, the board can also be connected to a PC via a USB connection. Demonstration software is included that audibly and visually demonstrates the powerful capabilities of the HS Series.



Master System Includes

- 2 HS Series Encoders*
- 2 HS Series Decoders*
- 1 LR or ES Series Transmitter*
- 1 LR or ES Series Receiver*
- 2 CW Series Antennas
- 2 Assembled Evaluation Boards
- 2 9V Batteries
- 1 Software / Documentation CD
- 1 USB Cable
- Full Documentation
- Free Technical Support

* Quantity includes those populated on the boards

Features

- On-Board RF Modules
- Easy Access to All Encoder, Decoder, and RF Module lines
- IR and Hardwire Key Exchange
- Efficient 1/4-Wave Antennas
- USB Interface
- User Prototyping Area
- 3V On-Board Regulation
- Assembled for Immediate Use

ORDERING INFORMATION

PART #	DESCRIPTION
MDEV-LICAL-HS	HS Series Master Development System w/ LR Series
MDEV-LICAL-HS-ES	HS Series Master Development System w/ ES Series

MT SERIES MASTER DEVELOPMENT SYSTEM

INTEGRATED CIRCUITS 5

This comprehensive development system is designed to assist in the rapid evaluation and integration of MT Series transcoders. The all-inclusive kit features pre-assembled evaluation boards, which have everything needed to quickly test the operation of the transcoders. The on-board Linx LT Series RF tranceiver provides a reliable link for wireless operation. When you are ready to begin development, a convenient prototyping area with breakout headers and regulated power supply allows for rapid testing and interface. In addition to its stand-alone functions, the board can also be connected to a PC via a USB connection. Demonstration software is included which audibly and visually demonstrates the powerful capabilities of the MT Series. Technical support for the kit and all on-board Linx products is included.



Master System Includes

- 2 Assembled Evaluation Boards
- 4 MT Series Transcoders*
- 2 LT Series Transceivers*
- 2 CW Series Antennas
- 2 9V Batteries
- 1 Software / Documentation CD
- 2 USB Cables
- Full Documentation
- Free Technical Support

* Quantity includes those populated on the boards

Features

- On-Board RF Modules
- Easy Access to All Transcoder and RF Module lines
- Efficient 1/4-Wave Antennas
- USB Interface
- User Prototyping Area
- 3V On-Board Regulation
- Assembled for Immediate Use

ORDERING INFORMATION

PART #	DESCRIPTION
MDEV-LICAL-MT	MT Series Master Development System w/ LT Series

Instant RF For Your Application



The Linx OEM-configurable RF product line greatly reduces the cost and time required to bring a wireless product to market. The line features a variety of low-cost generic command and control modules that can be customized to meet specific OEM labeling requirements. Since these products have received prior FCC, IC and CE approval, the time and expense of bringing a product to market is significantly reduced. Available in frequencies from 315 to 433MHz, the modules are divided into two classes: command modules and function modules.

Command modules include complete handheld and keyfob transmitters capable of sending multiple commands to an unlimited number of function modules. The command module's transmissions may be received by a compatible Linx RF module incorporated in a user's discrete circuit or by a Linx function module. Function modules contain a receiver and decoder to interpret the signal sent by the command module and then perform switching and control functions. The command module's transmissions may also be received by the Linx LR, KH, or LT family of RF modules.

HOLTEK-BASED COMMAND MODULES

PART #	DESCRIPTION	PG.
CMD-KEY#-***-xxx	Keyfob Transmitter	72
CMD-HHCP-***-xxx-MD	Compact Handheld Transmitter	73
CMD-HHLR-***-xxx-MD	Long-Range Handheld Transmitter	74
CMD-HHTX-***-xxx	Full-Size Handheld Transmitter	75

HOLTEK-BASED FUNCTION MODULE

FCTN-RLY4-***	Relay Function Module	76
FCTN-WALL-***	AC Function Module	77

EVALUATION KITS

EVAL-***-KF	Keyfob Basic Evaluation Kit	78
EVAL-***-HHCP	Compact Handheld Basic Evaluation Kit	78
EVAL-***-HHLR	Long-Range Handheld Basic Evaluation Kit	78
EVAL-***-HHTX	Full-Size Handheld Basic Evaluation Kit	78

*** See Ordering Information for available frequencies

DESCRIPTION

The Linx CMD-KEY#-***-xxx Keyfob transmitter is ideal for general-purpose remote control and command applications. It has been pre-certified for FCC Part 15, Industry Canada, and European CE (433MHz only) compliance, reducing development costs and time to market. Available in 315, 418 (standard), or 433.92MHz, this stylish and compact remote has a range of up to 750 feet when combined with the LR Series receiver. The Keyfob can be configured with 1 to 5 buttons and the keypad and labeling can be modified to meet specific customer requirements. Selectable addressing provides security and allows the creation of up to 1,024 distinct transmitter-receiver relationships. The Keyfob is available in black, white, or translucent colors. The transmission can be decoded using a matching Linx Function Module, KH Series receiver / decoder, or an LR or LT Series receiver paired with a decoder IC or microcontroller. The unit operates from a single 3V CR2032 lithium button cell.

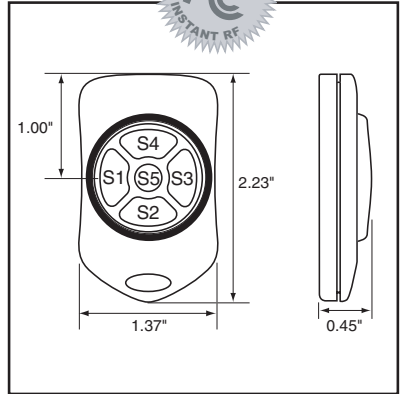

PHYSICAL DIMENSIONS



FEATURES

- FCC, Canada, and CE pre-certified
- 1 to 5 buttons
- Small package
- Customizable keypad

OEM Configurations

With a one-time NRE and minimum order, Linx can configure the keypad and label areas to meet your specific requirements. Contact Linx for details.

APPLICATIONS INCLUDE

- General Remote Control
- Keyless Entry
- Garage / Gate Openers
- Lighting Control
- Call Systems
- Home / Industrial Automation
- Wire Elimination

ORDERING INFORMATION

PART #	DESCRIPTION
CMD-KEY#-***-xxx	Keyfob Transmitter
EVAL-***-KF	Keyfob Basic Evaluation Kit
# = Number of Buttons: 1 to 5	
*** = 315, 418 (Standard), 433MHz	
xxx = Color Leave blank for standard Black	
WHT = White	CGY = Gray CBL = Blue
CRE = Red	CPU = Purple

PRE-CERTIFIED OEM PRODUCTS 6



DESCRIPTION

The CMD-HHCP-***-xxx-MD Compact Handheld transmitter is ideal for general remote control and command applications. It has been pre-certified for FCC Part 15, Industry Canada, and European CE (433MHz only) compliance, reducing development costs and time to market. Available in 315, 418 (standard), or 433.92MHz, this compact remote has a transmission range of up to 750 feet when combined with the LR Series receiver. The transmitter unit can be configured with 1 to 8 buttons and the keypad and labeling can be modified to meet specific OEM customer requirements. Selectable addressing provides security and allows the creation of up to 1,024 distinct transmitter-receiver relationships. The address can be easily changed via an externally accessible DIP switch. The transmission can be decoded using a matching Linx Function Module, KH Series receiver / decoder, or a Linx LR or LT Series receiver paired with a decoder IC or microcontroller. The unit uses a single 3V CR2032 lithium button cell.

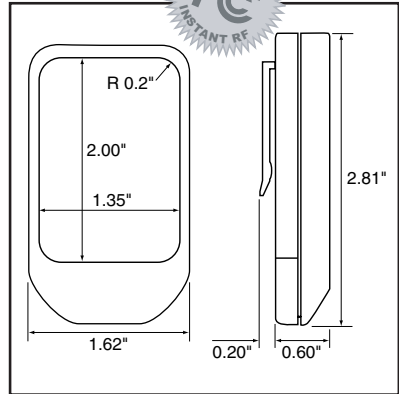

PHYSICAL DIMENSIONS



OEM Configurations

With a one-time NRE and minimum order, Linx can configure the keypad and label areas to meet your specific requirements. Contact Linx for details.

FEATURES

- FCC, Canada, and CE pre-certified
- 1 to 8 buttons
- Small package
- Customizable keypad

APPLICATIONS INCLUDE

- General Remote Control
- Keyless Entry
- Garage / Gate Openers
- Lighting Control
- Call Systems
- Home / Industrial Automation
- Wire Elimination

ORDERING INFORMATION	
PART #	DESCRIPTION
CMD-HHCP-***-xxx-MD	Compact Handheld Transmitter
EVAL-***-HHCP	HHCP Basic Evaluation Kit
*** = 315, 418 (Standard), 433MHz	
xxx = Custom color Leave blank for standard Black	

6 PRE-CERTIFIED OEM PRODUCTS



DESCRIPTION

The Linx CMD-HHLR-***-xxx-MD Long-Range Handheld transmitter is ideal for general-purpose remote control and command applications that require longer transmission distances. This unit has been pre-certified for FCC Part 15, Industry Canada, and European CE (433MHz only) compliance, reducing costs and time to market. Available in 315, 418 (standard), or 433.92MHz, this small remote has a transmission range of up to 1,000 feet when combined with the LR Series receiver. The transmitter unit can be configured with 1 to 8 buttons and the keypad and labeling can be modified to meet specific OEM customer requirements. Selectable addressing provides security and allows the creation of up to 1,024 distinct transmitter-receiver relationships. The address can be easily changed via an externally accessible DIP switch. The transmission can be decoded using a matching Linx Function Module, KH Series receiver / decoder, or a Linx LR or LT Series receiver paired with a decoder IC or microcontroller. The unit uses a single 3V CR2032 lithium button cell.

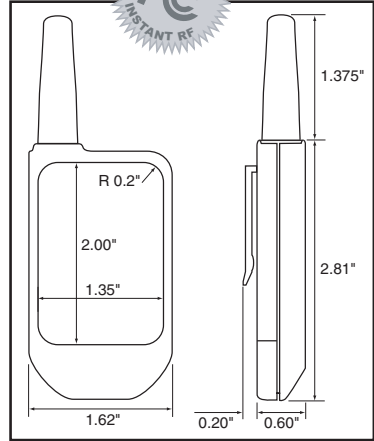

PHYSICAL DIMENSIONS



FEATURES

- FCC, Canada, and CE pre-certified
- 1 to 8 buttons
- Small package
- Customizable keypad

APPLICATIONS INCLUDE

- General Remote Control
- Keyless Entry
- Garage / Gate Openers
- Lighting Control
- Call Systems
- Home / Industrial Automation
- Wire Elimination

OEM Configurations

With a one-time NRE and minimum order, Linx can configure the keypad and label areas to meet your specific requirements. Contact Linx for details.

ORDERING INFORMATION

PART #	DESCRIPTION
CMD-HHLR-***-xxx-MD	Long-Range Handheld Transmitter
EVAL-***-HHLR	HHLR Evaluation Kit
*** = 315, 418 (Standard), 433MHz	
xxx = Custom color Leave blank for standard Black	



DESCRIPTION

The Linx CMD-HHTX-*** Full-Size Handheld Transmitter is ideal for general-purpose remote control and command applications. It has been pre-certified for FCC Part 15 compliance, which reduces costs and time to product introduction. Available in 315, 418 (standard) or 433.92MHz, this handheld transmitter is capable of transmission ranges of up to 750 feet when combined with the LR Series receiver. The transmitter unit can be configured with 1 to 8 buttons and the keypad and labeling can be modified to meet specific customer requirements. Selectable addressing provides security and allows the creation of up to 256 distinct transmitter-receiver relationships. The transmission can be decoded using a matching Linx function module, a Linx KH Series receiver / decoder or Linx LR or LT Series receiver paired with a decoder IC or microcontroller. The unit operates from a single 3V CR2032 lithium button cell.

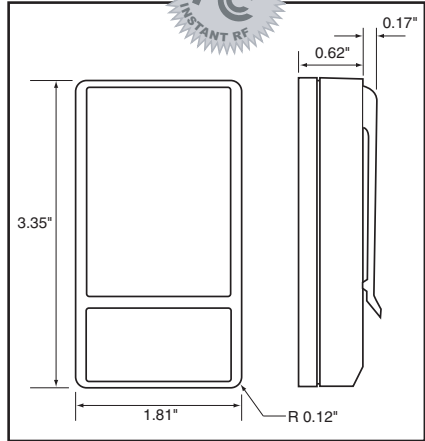

PHYSICAL DIMENSIONS

FEATURES

- FCC pre-certified
- 1 to 8 buttons
- Small package
- Customizable keypad

APPLICATIONS INCLUDE

- General Remote Control
- Keyless Entry
- Garage / Gate Openers
- Lighting Control
- Call Systems
- Home / Industrial Automation
- Wire Elimination



OEM Configurations

With a one-time NRE and minimum order, Linx can configure the keypad and label areas to meet your specific requirements. Contact Linx for details.

6 PRE-CERTIFIED OEM PRODUCTS

ORDERING INFORMATION	
PART #	DESCRIPTION
CMD-HHTX-***	Full-Size Handheld Transmitter
EVAL-***-HHTX	HHTX Evaluation Kit
*** = 315, 418 (Standard), 433MHz	



DESCRIPTION

The Relay Function Module 2 is a member of the Linx pre-certified OEM product line. The modules have been tested for FCC, Industry Canada, and European CE (433MHz only) compliance and can be quickly customized to meet a specific OEM's labeling requirements. This greatly reduces the time and expense of bringing an RF-based product to market. The Relay Function Modules provide four latched or momentary relay outputs that are capable of switching external AC or DC powered loads of up to 7 amps. The Relay Modules incorporate a Linx LR Series receiver. Selectable addressing provides security and allows the creation of 256 distinct transmitter / receiver relationships to avoid unwanted interaction when multiple systems are in use. When paired with a compatible Holtek based Linx OEM Handheld transmitter or transmitter module, the Relay Function Module 2 serves as a reliable wireless switching device at distances of up to 750 feet.

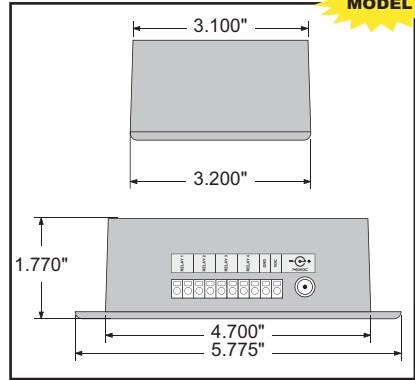

PHYSICAL DIMENSIONS

PRE-CERTIFIED OEM PRODUCTS 6

FEATURES

- FCC, Canada, and CE pre-tested
- Wide operational voltage (7 to 30VDC)
- Dual power inputs
- 4 long-life relays, switch AC or DC
- Flange-mount case
- Quick-attach heavy-duty device connectors
- 256 unique addresses
- Can be cosmetically customized for OEM applications.

APPLICATIONS INCLUDE

- General Remote Control
- Motor Control
- Garage / Gate Openers
- Lighting Control
- Home / Industrial
- Switching of AC or DC Voltages

ORDERING INFORMATION

PART #	DESCRIPTION
FCTN-RLY4-315-2	Relay Function Module 2 - 315MHz
FCTN-RLY4-418-2	Relay Function Module 2 - 418MHz
FCTN-RLY4-433-2	Relay Function Module 2 - 433MHz



DESCRIPTION

The AC Function Module is a member of the Linx pre-certified OEM product line. The module plugs directly into a wall receptacle and is capable of switching devices at loads of up to 1,800 watts (15 amps) or 1HP at up to 120VAC. Devices under control connect via a standard NEMA 5-15 North American power plug. The AC Function module has been UL approved and tested for FCC and Industry Canada compliance. Front and rear graphics can be quickly customized for a truly unique product appearance. The AC Function Module is durably constructed using high quality components. When paired with a compatible Holtek-based Linx Handheld transmitter or a Linx transmitter module, the AC Function Module provides reliable wireless switching over distances of up to 500 feet.

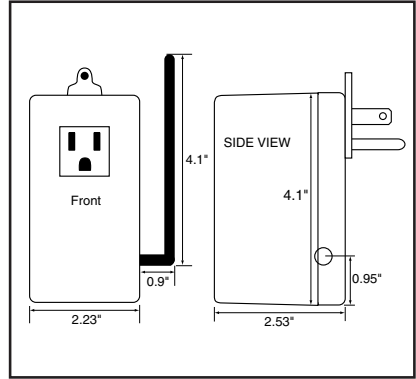

PHYSICAL DIMENSIONS

FEATURES

- Heavy duty construction
- Switch 1,800 watts at 15 amps
- UL Approved
- FCC pre-tested
- 16 unique addresses
- Selectable group capabilities
- Standard NEMA 5-15 power plug
- Easy cosmetic customization
- Ideal for OEM applications



APPLICATIONS INCLUDE

- General Remote Control
- Process Control
- Lighting Control
- Home / Industrial
- Wire Elimination



OEM Configurations

With a one-time NRE and minimum order, Linx can configure the keypad and label areas to meet your specific requirements. Contact Linx for details.

6 PRE-CERTIFIED OEM PRODUCTS

ORDERING INFORMATION

PART #	DESCRIPTION
FCTN-WALL-315	AC Function Module - 315MHz
FCTN-WALL-418	AC Function Module - 418MHz
FCTN-WALL-433	AC Function Module - 433MHz

KEYFOB BASIC EVALUATION KIT

The keyfob evaluation is an ideal starting point to evaluate the performance of Linx's popular keyfob transmitters and begin integration into your product. The FCC pre-certified keyfobs allow OEMs to rapidly incorporate wireless functions in a variety of remote control and command applications. The kit contains two keyfob transmitters along with a pre-assembled development board based on the KH2 Series receiver module. The development board features audible and visual indication for range testing and a small prototyping area with a signal breakout header.



PRE-CERTIFIED OEM PRODUCTS 6

Basic Kit Includes

- 1 Assembled Evaluation Board
- 2 Keyfob Transmitters
- 2 KH2 Series Receiver Modules*
- 1 CW Series Antenna
- 2 CONREVSMA001 Connectors*
- 2 AAA Batteries

* Quantity includes those populated on the boards

- 1 Ea. Tx and Rx Manuals
- Part 2 + Part 15 Guidelines
- Free Technical Support
- Inserts for 1 to 5 Buttons

ORDERING INFORMATION

PART #	DESCRIPTION
EVAL-***-KF	Keyfob Basic Evaluation Kit
*** = 315, 418 (Standard), 433MHz	

HANDHELD SERIES BASIC EVALUATION KIT

This basic development system allows for rapid testing of Linx's popular handheld transmitters and speeds integration into your own product. The FCC pre-certified HHLR, HHCP, and HHTX transmitters allow OEMs to rapidly incorporate wireless functions in a variety of wireless products. The kit contains two transmitters, along with a pre-assembled development board based on the KH2 Series receiver module. An antenna, battery, extra LR receiver and decoder, and full documentation are also provided.



Basic Kit Includes

- 1 Assembled Evaluation Board
- 2 HH Series Transmitters
- 2 KH2 Series Receiver Modules*
- 2 CONREVSMA001 Connectors*
- 1 CW Series Antenna
- 2 AAA Batteries
- 1 Ea. Tx and Rx Manuals
- Part 2 + Part 15 Guidelines
- Free Technical Support

ORDERING INFORMATION

PART #	DESCRIPTION
EVAL-***-HHTX	Full-Size Handheld Eval Kit
EVAL-***-HHCP	Compact Handheld Eval Kit
EVAL-***-HHLR	Long-Range Handheld Eval Kit
*** = 315, 418 (Standard), 433MHz	

* Quantity includes those populated on the boards

Instant RF For Your Application



This second generation of the Linx pre-approved OEM product line makes use of the new LR Series transmitter and the advanced MS and HS Series of encoders and decoders to provide greater range and reliability than the Holtek-based products. The MS Series encoder does away with the DIP switches and cut traces of the previous generation, offering over 16,000,000 unique addresses, as compared to 1,024. This greatly increases security and uniqueness. The HS Family uses CipherLinx®, a remote control encryption technology that provides ultimate RF security and unprecedented features. Furthermore, the individual transmitters can be given button-level access permissions. This controls which individual buttons each transmitter has the authority to activate. This provides a great deal of versatility in setting up a system.

The line includes handheld and keyfob transmitters capable of sending multiple commands to an unlimited number of receivers. The transmissions can be received by an LR or LT RF module with a matching MS or HS Series decoder IC.

6 PRE-CERTIFIED OEM PRODUCTS

MS / HS-BASED COMMAND MODULES

PART #	DESCRIPTION	PG.
OTX-***-HH-KF#-MS	MS Keyfob Transmitter	82
OTX-***-HH-CP8-MS	MS Compact Handheld Transmitter	83
OTX-***-HH-LR8-MS	MS Long-Range Handheld Transmitter	84
OTX-***-HH-CP8-HS	HS Compact Handheld Transmitter	86
OTX-***-HH-LR8-HS	HS Long-Range Handheld Transmitter	87

MS / HS-BASED DEVELOPMENT SYSTEMS

MDEV-***-HH-KF-MS	MS Keyfob Master Development System	85
MDEV-***-HH-CP8-MS	MS Compact Handheld Master Dev. System	85
MDEV-***-HH-LR8-MS	MS Long-Range Handheld Master Dev. System	85
MDEV-***-HH-CP8-HS	HS Compact Handheld Master Dev. System	88
MDEV-***-HH-LR8-HS	HS Long-Range Handheld Master Dev. System	88

*** See Ordering Information for available frequencies

DESCRIPTION

The Linx MS Series Keyfob transmitter is ideal for remote control and command applications. Available in 315, 418 (standard), or 433.92MHz versions, it has been pre-certified for FCC Part 15, Industry Canada, and European CE (433MHz) compliance. This dramatically reduces development cost and time to market. The high-performance synthesized design provides superior frequency accuracy and minimizes body proximity effects. When combined with an LR or LT Series module, the Keyfob can operate at distances of up to 750 feet. Ease of use and security are dramatically enhanced by the on-board MS Series encoder, which allows instant creation of up to 16,777,216 (2²⁴) unique addresses without cumbersome DIP switches or cut traces. When paired with a MS Series decoder, Keyfob identity can be determined and button permissions established. The Keyfob is available with 1 to 5 buttons and can be custom labeled.

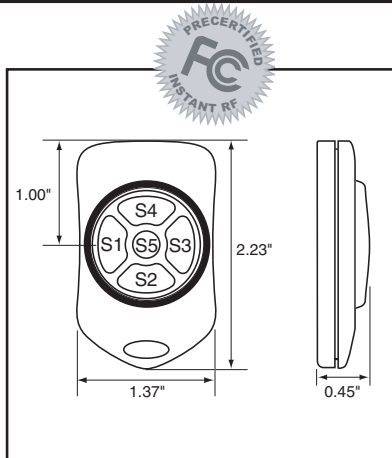

PHYSICAL DIMENSIONS



OEM Configurations

With a one-time NRE and minimum order, Linx can configure the keypad and label areas to meet your specific requirements. Contact Linx for details.

FEATURES

- FCC, Canada, and CE pre-certified
- Utilizes the advanced MS encoder
- 2²⁴ unique addresses
- 1 to 5 buttons
- Small package
- Customizable keypad

APPLICATIONS INCLUDE

- General Remote Control
- Keyless Entry
- Garage / Gate Openers
- Lighting Control
- Call Systems
- Home / Industrial Automation
- Wire Elimination

ORDERING INFORMATION

PART #	DESCRIPTION
OTX-***-HH-KF#-MS-xxx	MS Keyfob Transmitter
MDEV-***-HH-KF-MS	MS Keyfob Master Dev. System
# = Number of Buttons: 1 to 5	
*** = 315, 418 (Standard), 433MHz	
xxx = Color Leave blank for standard Black	
WHT = White	CGY= Gray CBL = Blue
CRE = Red	CPU = Purple



DESCRIPTION

The Linx OTX-***-HH-CP8-MS Compact Handheld Transmitter is ideal for general-purpose remote control and command applications. This unit has been pre-certified for FCC Part 15, Industry Canada, and European CE (433MHz only) compliance, reducing costs and time to market. Available in 315, 418 (standard), or 433.92MHz, this compact remote has a transmission range of up to 750 feet when combined with an LR or LT Series module. The transmitter unit can be configured with 1 to 8 buttons and the keypad and labeling can be modified to meet specific OEM customer requirements. Ease of use and security are dramatically enhanced by an on-board MS Series encoder, which allows instant creation of up to 16,777,216 (2²⁴) unique addresses without cumbersome DIP switches or cut traces. When paired with an MS Series decoder, transmitter identity can be determined and button permissions established. The unit uses a single 3V CR2032 lithium button cell.

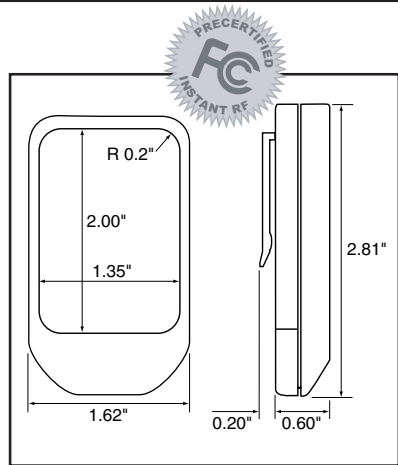

PHYSICAL DIMENSIONS



OEM Configurations

With a one-time NRE and minimum order, Linx can configure the keypad and label areas to meet your specific requirements. Contact Linx for details.

FEATURES

- FCC, Canada, and CE pre-certified
- Utilizes the advanced MS encoder
- 2²⁴ unique addresses
- 1 to 8 buttons
- Small package
- Customizable keypad

APPLICATIONS INCLUDE

- General Remote Control
- Keyless Entry
- Garage / Gate Openers
- Lighting Control
- Call Systems
- Home / Industrial Automation
- Wire Elimination

ORDERING INFORMATION

PART #	DESCRIPTION
OTX-***-HH-CP8-MS-xxx	MS Compact Handheld Transmitter
MDEV-***-HH-CP8-MS	HH-CP8 Master Development System
*** = 315, 418 (Standard), 433.92MHz	
xxx = Color Leave blank for standard Black	



DESCRIPTION

The Linx OTX-***-HH-LR8-MS Long-Range Handheld Transmitter is ideal for general-purpose remote control and command applications that require longer transmission distances. This unit has been pre-certified for FCC Part 15, Industry Canada, and European CE (433MHz only) compliance, reducing costs and time to market. Available in 315, 418 (standard), or 433.92MHz, this small remote has a transmission range of up to 1,000 feet when combined with an LR or LT Series module. The transmitter unit can be configured with 1 to 8 buttons and the keypad and labeling can be modified to meet specific OEM customer requirements. Ease of use and security are dramatically enhanced by the on-board MS Series encoder, which allows instant creation of up to 16,777,216 (2²⁴) unique addresses without cumbersome DIP switches or cut traces. When paired with an MS Series decoder, transmitter identity can be determined and button permissions established. The unit uses a single 3V CR2032 lithium button cell.

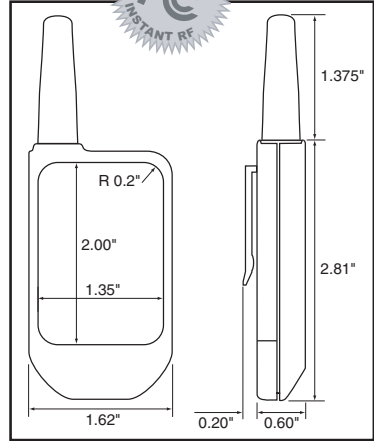

PHYSICAL DIMENSIONS



OEM Configurations

With a one-time NRE and minimum order, Linx can configure the keypad and label areas to meet your specific requirements. Contact Linx for details.

FEATURES

- FCC, Canada, and CE pre-certified
- Utilizes the advanced MS encoder
- 2²⁴ unique addresses
- 1 to 8 buttons
- Small package
- Customizable keypad

APPLICATIONS INCLUDE

- General Remote Control
- Keyless Entry
- Garage / Gate Openers
- Lighting Control
- Call Systems
- Home / Industrial Automation
- Wire Elimination

ORDERING INFORMATION

PART #	DESCRIPTION
OTX-***-HH-LR8-MS-xxx	MS Long-Range Transmitter
MDEV-***-HH-LR8-MS	HH-LR8 Master Development System
*** = 315, 418 (Standard), 433.92MHz	
xxx = Color Leave blank for standard Black	

MS KEYFOB MASTER DEVELOPMENT SYSTEM

The Keyfob Master Development System is an ideal starting point to evaluate the performance of Linx's popular Keyfob transmitters and begin integration into your product. The FCC pre-certified keyfobs allow OEMs to rapidly incorporate wireless functions in a variety of remote control and command applications. The development system contains two Keyfob transmitters along with a pre-assembled development board based on the LR Series receiver module and the MS Series decoder. The development board features audible and visual indication for range testing and a small prototyping area with a signal breakout header.



Master Dev. System Includes

- 1 Assembled Evaluation Board
- 2 Keyfob Transmitters
- 2 LR Series Receiver Modules*
- 2 MS Series Decoders*
- 1 CW Series Antenna
- 1 9V Battery

- 1 USB Cable
- Full Documentation
- Free Technical Support
- Inserts for 1 to 5 Buttons

* Quantity includes those populated on the boards

ORDERING INFORMATION

PART #	DESCRIPTION
MDEV-***-HH-KF-MS	MS Keyfob Master Dev. System
*** = 315, 418 (Standard), 433MHz	

MS HANDHELD MASTER DEVELOPMENT SYSTEMS

The MS Handheld Master Development System allows for rapid testing of Linx's popular handheld transmitters, and speeds integration into your own product. The FCC pre-certified MS HHLR and MS HHCP transmitters allow OEMs to rapidly incorporate wireless functions in a variety of wireless products. The kit contains two transmitters, along with a pre-assembled development board based on the LR Series receiver module and MS Series decoder. An antenna, battery, extra LR receiver and decoder, and full documentation are also provided.



Master Dev. System Includes

- 1 Assembled Evaluation Board
- 2 HH Series Transmitters
- 2 LR Series Receiver Modules*
- 2 MS Series Decoders*
- 1 CW Series Antenna
- 1 9V Battery
- 1 USB Cable
- Full Documentation
- Free Technical Support

ORDERING INFORMATION

PART #	DESCRIPTION
MDEV-***-HH-CP8-MS	Compact Handheld Master Dev.
MDEV-***-HH-LR8-MS	Long-Range Handheld Master Dev.
*** = 315, 418 (Standard), 433MHz	

* Quantity includes those populated on the boards

6 PRE-CERTIFIED OEM PRODUCTS



DESCRIPTION

The Linx OTX-***-HH-CP8-HS Compact Handheld Transmitter is ideal for general-purpose remote control and command applications which require high security. This unit has been pre-certified for FCC Part 15, Industry Canada, and European CE (433MHz only) compliance, reducing costs and time to market. Available in 315, 418 (standard), or 433.92MHz, this small remote has a transmission range of up to 750 feet when combined with an LR or LT Series module. The transmitter unit can be configured with 1 to 8 buttons and the keypad and labeling can be modified to meet specific OEM customer requirements. Security is dramatically enhanced by the on-board HS Series encoder, which uses Cipherlinx[®] technology, a high-security encryption algorithm and wireless protocol. When paired with an HS Series decoder, transmitter identity can be determined and button permissions established. The unit uses a single 3V CR2032 lithium button cell.

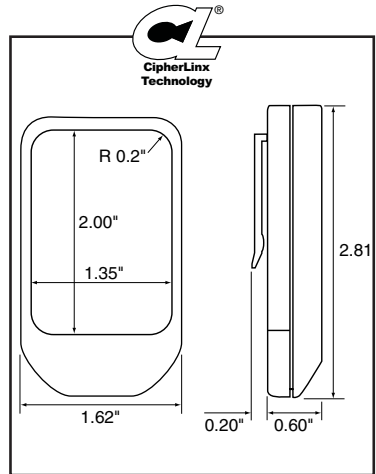

PHYSICAL DIMENSIONS



OEM Configurations

With a one-time NRE and minimum order, Linx can configure the keypad and label areas to meet your specific requirements. Contact Linx for details.

FEATURES

- FCC, Canada, and CE pre-certified
- CipherLinx[®] Technology
- Highly secure, encrypted transmission
- 1 to 8 buttons
- Small package
- Customizable keypad

APPLICATIONS INCLUDE

- Secure Remote Control
- Keyless Entry
- Garage / Gate Openers
- Lighting Control
- Call Systems
- Home / Industrial Automation
- Wire Elimination

ORDERING INFORMATION

PART #	DESCRIPTION
OTX-***-HH-CP8-HS-xxx	HS Compact Handheld Transmitter
MDEV-***-HH-CP8-HS	HH-CP8 Master Development System
*** = 315, 418 (Standard), 433.92MHz	
xxx = Reserved for custom colors. Leave blank for standard black	

PRE-CERTIFIED OEM PRODUCTS 6

LINX® HS LONG-RANGE HANDHELD TRANSMITTER

TECHNOLOGIES
WIRELESS MADE SIMPLE®



DESCRIPTION

The Linx OTX-***-HH-LR8-HS Long-Range Handheld Transmitter is ideal for general-purpose remote control and command applications which require high security and long transmission distances. This unit has been pre-certified for FCC Part 15, Industry Canada, and European CE (433MHz only) compliance, reducing costs and time to market. Available in 315, 418 (standard), or 433.92MHz, this small remote has a transmission range of up to 1,000 feet when combined with an LR or LT Series module. The transmitter unit can be configured with 1 to 8 buttons and the keypad and labeling can be modified to meet specific OEM customer requirements. Security is dramatically enhanced by the on-board HS Series encoder, which uses Cipherlinx® technology, a high-security encryption algorithm and wireless protocol. When paired with an HS Series decoder, transmitter identity can be determined and button permissions established. The unit uses a single 3V CR2032 lithium button cell.

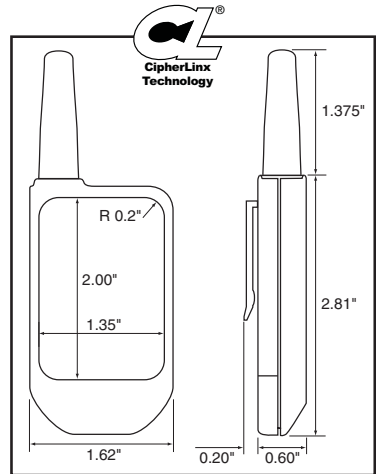

Figure 1: Package Dimensions

FEATURES

- FCC, Canada, and CE pre-certified
- CipherLinx® Technology
- Highly secure, encrypted transmission
- 1 to 8 buttons
- Small package
- Customizable keypad

APPLICATIONS INCLUDE

- Secure Remote Control
- Keyless Entry
- Garage / Gate Openers
- Lighting Control
- Call Systems
- Home / Industrial Automation
- Wire Elimination



OEM Configurations

With a one-time NRE and minimum order, Linx can configure the keypad and label areas to meet your specific requirements. Contact Linx for details.

ORDERING INFORMATION	
PART #	DESCRIPTION
OTX-***-HH-LR8-HS-xxx	HS Long-Range Transmitter
MDEV-***-HH-LR8-HS	HH-LR8 Master Development System
*** = 315, 418 (Standard), 433.92MHz	
xxx = Reserved for custom colors. Leave blank for standard black	

6 PRE-CERTIFIED OEM PRODUCTS

HS HANDHELD MASTER DEVELOPMENT SYSTEMS

The HS Handheld Master Development System allows for rapid testing of Linx's handheld transmitters, and speeds integration into your own product. The FCC pre-certified HS HHLR and HS HHCP transmitters are based upon the HS Series encoder, which uses CipherLinx[®] Technology an encrypted remote control technology that provides ultimate RF security and unprecedented features. The kit contains two transmitters, along with a pre-assembled development board based on the LR Series receiver module and HS Series decoder. An antenna, battery, extra LR receiver and HS decoder, and full documentation are also provided.



Master Dev. System Includes

- 1 Assembled Evaluation Board
- 2 HH Series Transmitters
- 2 LR Series Receiver Modules*
- 2 HS Series Decoders*
- 1 CW Series Antenna
- 1 9V Battery
- 1 USB Cable
- Full Documentation
- Free Technical Support

ORDERING INFORMATION

PART #	DESCRIPTION
MDEV-***-HH-CP8-HS	Compact Handheld Master Dev.
MDEV-***-HH-LR8-HS	Long-Range Handheld Master Dev.
*** = 315, 418 (Standard) , 433MHz	

* Quantity includes those populated on the boards

PRE-CERTIFIED OEM PRODUCTS 6

SILICONE BOOT FOR HANDHELD TRANSMITTER **NEW**

Minimize the risk of damage and give your OEM transmitter a distinctive product look. These durable, rubberized skins provide enhanced protection from scratches, bumps, and minor falls for any Linx OEM compact or long-range handheld transmitter. The rugged skin is a perfect way to protect transmitters in challenging consumer and industrial environments. An included belt clip accommodates the extra thickness of the skin while also providing an attachment point for the optional leash. Custom colors are available for high volume orders.



ORDERING INFORMATION

PART #	DESCRIPTION
OTX-ACC-BOOT-HH-***	HH SILICONE BOOT
*** = GRY (Gray), BLK (Black)	
<i>Also available as a factory installed option. Please call for details.</i>	

8.5" LEASH **NEW**

The 8.5 inch leash is fitted with a carabineer at one end and a cell phone-type loop at the other. This allows for convenient carrying alternatives or attachment to fixed equipment. Custom colors are available for high volume orders.



ORDERING INFORMATION

PART #	DESCRIPTION
OTX-ACC-LSH-8.5	HH 8.5" LEASH WITH CLIP

RETRACTABLE REELS **NEW**

Two different styles of retractable reels are available for your handheld transmitter or keyfob. The RTR-32 is a light duty, plastic model while the RTR-CLP is a medium duty metal model. These reels allow for convenient carrying and usage of your chosen product. Both models include a rear belt clip and CLP-MD model includes an additional gate carabiner clip on top. Custom colors are available for high volume orders.



ORDERING INFORMATION

PART #	DESCRIPTION
OTX-ACC-RTR-32-LD	RETRACT. REEL, 32mm DIA.
OTX-ACC-RTR-CLP-MD	RETRACT. REEL, CARABINER CLIP

The Final Link to Ultimate RF Performance!



Linx Technologies offers a wide variety of cost-effective PCB and bulkhead RP-SMA connectors. The high-quality connectors featured in this guide are designed to mate with Antenna Factor connectorized antennas. Linx Technologies also offers many additional styles. Visit www.linxtechnologies.com for full details.

CONNECTORS

Series	DESCRIPTION	PG.
RP-SMA	Reverse Polarity Sub-Miniature A	92
SMA	Sub-Miniature A	95
MCX	Micro Coax	98
RP-MCX	Reverse Polarity Micro Coax	100
MMCX	Micro Miniature Coax	102
N	Type N	103
Adaptors	Between Series Adaptors	103
Cable Assemblies	Stock Cable Assemblies	104
Crimp Kits	Crimper and Die Kits	106
Battery Holder	CR2032 Coin Cell Battery Holder	106
Custom Cable Assemblies	Create Your Own Custom Cable Assembly	107



CONREVSMA001
RP-SMA Female PCB Mount



CONREVSMA001-SMD
RP-SMA Female Surface Mount



CONREVSMA002
RP-SMA Female Right Angle PCB Mount



CONREVSMA002-SMD
RP-SMA Female Right Angle Surface Mount



CONREVSMA002-L
RP-SMA Female Right Angle PCB Mount - Extended



CONREVSMA003.031
RP-SMA Female Edge Mount for 0.031" Thick PCB

CONREVSMA003.062
RP-SMA Female Edge Mount for 0.062" Thick PCB



CONREVSMA003.031-L
RP-SMA Female Edge Mount for 0.031" Thick PCB - Extended

CONREVSMA003.062-L
RP-SMA Female Edge Mount for 0.062" Thick PCB - Extended



CONREVSMA004
RP-SMA Female Bulkhead Front Mount



CONREVSMA005

RP-SMA Female Bulkhead Mount for RG-174 Cable

CONREVSMA005-R178

RP-SMA Female Bulkhead Mount for RG-178 Cable

CONREVSMA005-R58

RP-SMA Female Bulkhead Mount for RG-58 Cable



CONREVSMA006.031

RP-SMA Female Edge Mount for 0.031" Thick PCB

CONREVSMA006.062

RP-SMA Female Edge Mount for 0.062" Thick PCB



CONREVSMA006.062SQ

RP-SMA Female Edge Mount for 0.062" Thick PCB, Square Flange



CONREVSMA007

RP-SMA Male Cable End Crimp for RG-174 Cable

CONREVSMA007-R178

RP-SMA Male Cable End Crimp for RG-178 Cable

CONREVSMA007-R58

RP-SMA Male Cable End Crimp for RG-58 Cable



CONREVSMA008

RP-SMA Female PCB Mount - Extended



CONREVSMA009

RP-SMA Female Right Angle Edge Multi-Mount



CONREVSMA010

RP-SMA Male to Female Right Angle Adaptor



CONREVSMA011

RP-SMA Female Cable End Crimp for RG-174 Cable

CONREVSMA011-R178

RP-SMA Female Cable End Crimp for RG-178 Cable

CONREVSMA011-R58

RP-SMA Female Cable End Crimp for RG-58 Cable



CONREVSMA012

RP-SMA Male Right Angle Cable End Crimp for RG-174 Cable

CONREVSMA012-R178

RP-SMA Male Right Angle Cable End Crimp for RG-178 Cable

CONREVSMA012-R58

RP-SMA Male Right Angle Cable End Crimp for RG-58 Cable



CONREVSMA013.031

RP-SMA Male Edge Mount for 0.031" Thick PCB

CONREVSMA013.062

RP-SMA Male Edge Mount for 0.062" Thick PCB



CONREVSMA014

RP-SMA Female Bulkhead Rear Mount Cable End Crimp w/ O-Ring for RG-174 Cable

CONREVSMA014-R178

RP-SMA Female Bulkhead Rear Mount Cable End Crimp w/ O-Ring for RG-178 Cable

CONREVSMA014-R58

RP-SMA Female Bulkhead Rear Mount Cable End Crimp w/ O-Ring for RG-58 Cable



CONREVSMA015

RP-SMA Female Bulkhead Front Mount Cable End Crimp w/ O-Ring for RG-174 Cable

CONREVSMA015-R178

RP-SMA Female Bulkhead Front Mount Cable End Crimp w/ O-Ring for RG-178 Cable

CONREVSMA015-R58

RP-SMA Female Bulkhead Front Mount Cable End Crimp w/ O-Ring for RG-58 Cable



CON SMA001
SMA Female PCB Mount



CON SMA001-SMD
SMA Female Surface Mount



CON SMA002
SMA Female Right Angle PCB Mount



CON SMA002-SMD
SMA Female Right Angle Surface Mount



CON SMA002-L
SMA Female Right Angle PCB Mount - Extended



CON SMA003.031
SMA Female Edge Mount for 0.031" Thick PCB

CON SMA003.062
SMA Female Edge Mount for 0.062" Thick PCB



CON SMA003.031-L
SMA Female Edge Mount for 0.031" Thick PCB - Extended

CON SMA003.062-L
SMA Female Edge Mount for 0.062" Thick PCB - Extended



CON SMA005

SMA Female Bulkhead Mount for RG-174 Cable

CON SMA005-R178

SMA Female Bulkhead Mount for RG-178 Cable

CON SMA005-R58

SMA Female Bulkhead Mount for RG-58 Cable



CON SMA006.031

SMA Female Edge Mount for 0.031" Thick PCB

CON SMA006.062

SMA Female Edge Mount for 0.062" Thick PCB



CON SMA007

SMA Male Cable End Crimp for RG-174 Cable

CON SMA007-R178

SMA Male Cable End Crimp for RG-178 Cable

CON SMA007-R58

SMA Male Cable End Crimp for RG-58 Cable



CON SMA008

SMA Female PCB Mount - Extended



CON SMA010

SMA Male to Female Right Angle Adaptor



CON SMA011

SMA Female Cable End Crimp for RG-174 Cable

CON SMA011-R178

SMA Female Cable End Crimp for RG-178 Cable

CON SMA011-R58

SMA Female Cable End Crimp for RG-58 Cable



CON SMA012

SMA Male Right Angle Cable End Crimp for RG-174 Cable

CON SMA012-R178

SMA Male Right Angle Cable End Crimp for RG-178 Cable

CON SMA012-R58

SMA Male Right Angle Cable End Crimp for RG-58 Cable



CON SMA013.031

SMA Male Edge Mount for 0.031" Thick PCB

CON SMA013.062

SMA Male Edge Mount for 0.062" Thick PCB



CON SMA014

SMA Female Bulkhead Rear Mount Cable End Crimp w/ O-Ring for RG-174 Cable

CON SMA014-R178

SMA Female Bulkhead Rear Mount Cable End Crimp w/ O-Ring for RG-178 Cable

CON SMA014-R58

SMA Female Bulkhead Rear Mount Cable End Crimp w/ O-Ring for RG-58 Cable



CON SMA015

SMA Female Bulkhead Front Mount Cable End Crimp w/ O-Ring for RG-174 Cable

CON SMA015-R178

SMA Female Bulkhead Front Mount Cable End Crimp w/ O-Ring for RG-178 Cable

CON SMA015-R58

SMA Female Bulkhead Front Mount Cable End Crimp w/ O-Ring for RG-58 Cable



CONMCXA001
MCX Female PCB Mount



CONMCX001-SMD
MCX Female Surface Mount



CONMCX002
MCX Female Right Angle PCB Mount



CONMCX002-SMD
MCX Female Right Angle Surface Mount



CONMCX003.031
MCX Female Edge Mount for 0.031" Thick PCB
CONMCX003.062
MCX Female Edge Mount for 0.062" Thick PCB



CONMCX003.031-L
MCX Female Edge Mount for 0.031" Thick PCB - Extended
CONMCX003.062-L
MCX Female Edge Mount for 0.062" Thick PCB - Extended



CONMCX004
MCX Female Bulkhead Rear Mount (Solder Cup)



CONMCX005
SMA Female Bulkhead Mount for RG-174 Cable
CONMCX005-R178
SMA Female Bulkhead Mount for RG-178 Cable



CONMCX007

MCX Male Cable End Crimp for RG-174 Cable

CONMCX007-R178

MCX Male Cable End Crimp for RG-178 Cable



CONMCX011

MCX Female Cable End Crimp for RG-174 Cable

CONMCX011-R178

MCX Female Cable End Crimp for RG-178 Cable



CONMCX012

MCX Male Right Angle Cable End Crimp for RG-174 Cable

CONMCX012-R178

MCX Male Right Angle Cable End Crimp for RG-178 Cable



CONREVMCX001
RP-MCX Female PCB Mount



CONREVMCX001-SMD
RP-MCX Female Surface Mount



CONREVMCX002-L
RP-MCX Female Right Angle PCB Mount - Extended



CONREVMCX002-SMD
RP-MCX Female Right Angle Surface Mount



CONREVMCX002-SMD-L
RP-MCX Female Right Angle Surface Mount - Extended



CONREVMCX003.062
RP-MCX Female Edge Mount for 0.062" Thick PCB



CONREVMCX003.062-L
RP-MCX Female Edge Mount for 0.062" Thick PCB - Extended



CONREVMCX005

RP-MCX Female Bulkhead Rear Mount for RG-174 Cable

CONREVMCX005-R178

RP-MCX Female Bulkhead Rear Mount for RG-178 Cable



CONREVMCX007

RP-MCX Male Cable End Crimp for RG-174 Cable

CONREVMCX007-R178

RP-MCX Male Cable End Crimp for RG-178 Cable



CONREVMCX011

RP-MCX Female Cable End Crimp for RG-174 Cable

CONREVMCX011-R178

RP-MCX Female Cable End Crimp for RG-178 Cable



CONREVMCX012

RP-MCX Male Right Angle Cable End Crimp for RG-174 Cable

CONREVMCX012-R178

RP-MCX Male Right Angle Cable End Crimp for RG-178 Cable



CONMMCX001
MMCX Female PCB Mount



CONMMCX001-SMD
MMCX Female Surface Mount



CONMMCX002
MMCX Female Right Angle PCB Mount



CONMMCX002-SMD
MMCX Female Right Angle Surface Mount



CONMMCX007
MMCX Male Cable End Crimp for RG-174 Cable

CONMMCX007-R178
MMCX Male Cable End Crimp for RG-178 Cable



CONMMCX011
MMCX Female Cable End Crimp for RG-174 Cable

CONMMCX011-R178
MMCX Female Cable End Crimp for RG-178 Cable



CONMMCX012
MMCX Male Right Angle Cable End Crimp for RG-174 Cable

CONMMCX012-R178
MMCX Male Right Angle Cable End Crimp for RG-178 Cable



CONN005

N Female Bulkhead Mount Cable End Crimp



CONN007

N Male Cable End Crimp



CONN011

N Female Cable End Crimp



CONN012

N Male Right Angle Cable End Crimp

ADAPTORS



ADP-SMAM-RPSF

SMA Male to RP-SMA Female Adaptor



ADP-SMAF-RPSM

SMA Female to RP-SMA Male Adaptor



ADP-SMAF-SMAF

SMA Female to SMA Female Adaptor



ADP-SMAM-SMAM

SMA Male to SMA Male Adaptor

C58LL-RPSM-2438-NM

RP-SMA Male to N Male w/ 8' RG-58 Cable



C58LL-SMAM-2438-NM

SMA Male to N Male w/ 8' RG-58 Cable



CONNECTORS 7

CONREVSMA014-C08.5 (8.5" Standard)

RP-SMA Female Bulkhead-Mount w/ 8.5" RG-174



CONREVSMA005-C08.5 (8.5" Standard)

RP-SMA Female Bulkhead-Mount w/ 8.5" RG-174



CSA-RPSM-216-RSFB

RP-SMA Male to RP-SMA Female Bulkhead Mount w/ 8.5" RG-174 Cable



CSA-RPSM-216-SAFB

RP-SMA Male to SMA Female Bulkhead Mount w/ 8.5" RG-174 Cable



CSA-SMAM-216-RSFB

SMA Male to RP-SMA Female Bulkhead Mount w/ 8.5" RG-174 Cable



CSA-SMAM-216-SAFB

SMA Male to SMA Female Bulkhead Mount w/ 8.5" RG-174 Cable



CRIMP KITS

These high quality crimping sets are ideal for low-volume connector assembly. Each kit includes a crimp frame and a cable cutter and stripper in a custom padded hard case. Model CTK-58-01 comes with a die insert for RG-58/59/62 cables. Model CTK-174-02 comes with two die inserts, one for RG-174/179 cables and one for RG-58/59/62 cables.



CONNECTORS 7

ORDERING INFORMATION	
PART #	DESCRIPTION
CTK-58-01	Crimp Kit for RG-58/59/62
CTK-174-02	Crimp Kit for RG-58/59/62/174/179

BATTERY HOLDER

This battery holder fits 20mm coin cell batteries. This low cost SMD holder provides a low profile while maintaining a secure hold on the battery. It is ideal for keyfobs, remote controls, and other small handheld devices.



ORDERING INFORMATION	
PART #	DESCRIPTION
BAT-HLD-001	20mm Coin Cell Battery Holder

CUSTOM CABLE ASSEMBLIES

Linx Technologies can produce cable assemblies for volume OEM customers. Specify the terminations, cable length, and cable type and Linx Technologies can deliver a high-quality assembly for a low cost. See our online custom cable assembly form at www.linxtechnologies.com.

Custom RF Coax Cable Assemblies

Do you need custom cable assemblies? Avoid the hassle of long wait times or high prices with our cable assembly designer. We'll make sure you get your cable assemblies quickly at a price you can afford.



Cable assembly specifications

Choose only in-stock components to get your cable assemblies even faster.

<p>Connector A - highlighted items in stock (required)</p> <ul style="list-style-type: none"> SMA Female Straight <li style="background-color: yellow;">SMA Female Bulkhead SMA Female Right Angle SMA Male Straight SMA Male Bulkhead SMA Male Right Angle 	<p>Connector B - highlighted items in stock (required)</p> <ul style="list-style-type: none"> RP-BNC <li style="background-color: blue; color: white;">RP-BNC Female Straight RP-BNC Male Straight RP-BNC Male Bulkhead BNC BNC Female Straight
<p>Cable type - highlighted items in stock (required)</p> <ul style="list-style-type: none"> RG-141A <li style="background-color: blue; color: white;">RG-178 RG-188A RG-196 RG-210 RG-213 	<p>Cable length [mm] - 100-300mm in stock (required)</p> <input style="width: 100%; height: 20px; border: 1px solid #ccc;" type="text"/> <p>Quantity (required)</p> <input style="width: 100%; height: 20px; border: 1px solid #ccc;" type="text"/>

Welcome to the Products & Services of



Phone: (541) 956-0931

Fax: (541) 471-6251

www.antennafactor.com

info@antennafactor.com

About Antenna Factor

Antenna Factor focuses on cost-effective standard and custom antennas designed for a wide range of consumer and industrial wireless products. With one of the broadest and most comprehensive antenna lines in the industry, we have helped companies of all sizes meet the mechanical, electrical, and aesthetic requirements of their wireless products. From tiny embeddable chip antennas to GPS and high-gain Yagi antennas, you can find them here.

Our specialty is compact antennas intended for use on compromised ground planes, such as those commonly found in handheld and portable products. We recognize that our components are a critical factor in determining the range and reliability of a wireless product. Making the correct design choices is often a balance of complex issues ranging from cosmetic attractiveness to legal considerations. We work with each customer to ensure optimum performance and satisfaction with our products.

Antenna Factor not only offers a broad range of standard products but can also deliver anything from a slight modification to a ground up antenna design. From color-to-shape, frequency-to-wavelength Antenna Factor stands ready to assist with your custom antenna requirements.

By combining responsive customer service, individualized technical support, world class quality, outstanding value and custom design capabilities, Antenna Factor hopes to be your antenna supplier of choice.

A Critical Component for Proper Performance!



The antenna is a critical and often overlooked RF component. A properly matched antenna is vital to achieving maximum range and reliable system performance. Antenna Factor offers a wide variety of antennas designed to offer outstanding performance at a cost-effective price. Visit www.antennafactor.com for full details.

ANTENNAS

SERIES	DESCRIPTION	CONNECTION	PG.
LP	Permanent-Mount Reduced-Height	PA-TAB	113
RA	Permanent-Mount Multi-Angle	PA-TAB	113
PW-QW	Permanent-Mount 1/4-Wave Whip	Stud-Mount	113
PMC	Permanent-Mount 360° Rotating	PA-TAB	114
PML	Permanent-Mount 90° Tilt	Stud-Mount	114
CW-QW	Connectorized 1/4-Wave Whip	RP-SMA or SMA	115
RH	Connectorized Reduced-Height	RP-SMA or SMA	116
HD	Connectorized Heavy-Duty Reduced-Height	RP-SMA	116
HW	Connectorized 1/2-Wave Dipole	RP-SMA or SMA	117
CT	Connectorized 1/2-Wave Dipole	RP-SMA or SMA	117
HWR	Connectorized Right-Angle Tilt-Swivel	RP-SMA or SMA	118
RCT	Connectorized Right-Angle Tilt-Swivel	RP-SMA or SMA	118
RCS	Connectorized Ultra-Compact Right-Angle	RP-SMA or SMA*	119
RCL	Connectorized Compact Right-Angle	RP-SMA	119
RAH	Connectorized Reduced-Height Right Angle	RP-SMA or SMA*	120
RAF	Connectorized Dual-Band Tilt-Swivel	RP-SMA or SMA	120
SP	Splatch Permanent-Mount Planar	Surface-Mount	121
JJB	Permanent-Mount Ultra-Miniature	Through-Hole	121
JJB-HT	Permanent-Mount Miniature	Through-Hole	122
CHP	Permanent-Mount Ultra-Compact Chip	Surface-Mount	122

(Continued on next page)

*Select frequencies. See Ordering Information for available frequencies

ANTENNAS (CON'T)

SERIES	DESCRIPTION	CONNECTION	PG.
HETH / HESM	Permanent-Mount Internal Helical	PCB Mount	123
MHW	Compct. Stick-On Ctr.-Fed Dipole w/ Cable	RP-SMA or SMA	124
HDP	Dual-Band Stick-On	Cable + RP-SMA, SMA or TNC	124
VDP	Tri-Band Stick-On	Cable + RP-SMA, SMA or TNC	125
RMS	Dual-Band Through-Hole Mount	Cable + RP-SMA or TNC	125
RMT	"Techno" Dual-Band Through-Hole Mount	Cable + RP-SMA, SMA or TNC	125
WRT	Low-Profile Dome	SMA, RP-SMA or U.FL*	126
WRT-MON	Tamper Resistant	SMA, RP-SMA, or U.FL	127
MAG	Magnetic Mount	Cable + RP-SMA or TNC	128
UC	GPS	Cable + SMA, RP-SMA or MCX	129
SH	GPS	Cable + SMA, MCX or MMCX	129
YG	Multi-Element Yagi High-Gain	N	130
OM	Omnidirectional	N	131
OM-DW	Omnidirectional	N	131
DB1-LP	Log Periodic	N	132
PN	Panel	N	132
ANT-SKN	Antenna Covers	-	133
CAEK	Connectorized Antenna Evaluation Kits		134
PAEK	Permanent-Mount Antenna Evaluation Kits		135
AEK-CHP	Chip Antenna Evaluation Kit	Surface-Mount	135
AEK-SP	Splatch Antenna Evaluation Kit	Surface-Mount	136

*Select frequencies. See Ordering Information for available frequencies

ANTENNA FACTOR PERMANENT-MOUNT ANTENNAS

ABOUT PERMANENT-MOUNT ANTENNAS

Permanent-mount antennas mount directly to a product's circuit board or enclosure, thereby eliminating the cost of a connector, and ensuring FCC compliance. These antennas are ideally suited to applications that require a compact, cost-effective antenna solution. Custom colors and logo options are available for volume orders.

LP SERIES ANTENNAS

LP Series antennas are low-cost, reduced-height, permanently attached 1/4-wave whips. They are ideal for applications requiring a rugged, cosmetically-attractive, yet cost-effective antenna solution. These antennas feature an internal helix, which greatly reduces the overall antenna height while offering near monopole performance.



ORDERING INFORMATION

PART #	DESCRIPTION
ANT-***-PW-LP	LP Perm. Reduced-Height
*** = 315, 418, 433, 868, 916MHz, 2.4GHz	

RA SERIES ANTENNAS

The RA Series offers maximum mounting and orientation flexibility in a cost-effective, reduced-height package. The antenna's innovative base allows a wide range of horizontal and vertical motions, enhancing versatility for both the designer and customer. The antenna mounts quickly to a PCB via a single screw and meets all Part 15 requirements.

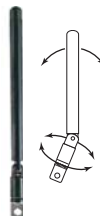

ORDERING INFORMATION

PART #	DESCRIPTION
ANT-***-PW-RA	RA Perm. Multi-Angle
*** = 315, 418, 433, 868, 916MHz	

PW SERIES ANTENNAS

PW Series antennas provide outstanding performance in a rugged and cost-effective package. The antenna is attached by placing its base through a 1/4" hole in the product and securing it with a nut or by threading it into a PEM-style insert. This method of attachment is secure and saves the cost of an antenna connector. The antenna is fed through the base with RG-174 coax cable that may be soldered directly to the board or attached using a 50-ohm connector. Standard cable length is 8.5". Custom lengths and terminations are available by special order. The 2.4GHz version is 1/2-wave, the rest are 1/4-wave.



ORDERING INFORMATION

PART #	DESCRIPTION
ANT-***-PW-QW	PW Perm w/ 8.5" Cable
*** = 418, 433, 868, 916MHz, 2.4GHz	

ANTENNA FACTOR PERMANENT-MOUNT ANTENNAS

PMC SERIES ANTENNAS

The PMC Series 1/4-wave antenna is a heavy-duty version of the PMB Series above. It features a stylish and rugged blade element and heavy-duty mounting base. The element can be rotated 360°.



ORDERING INFORMATION

PART #	DESCRIPTION
ANT-868/916-PMC	PMC Perm. 360° Rotating

PML SERIES ANTENNAS

This innovative 1/2-wave antenna with 90° tilt is attached by placing its base through a 1/4" hole in the product and securing it with a nut or by threading it into a PEM-style insert. It attaches to a PCB or connector via an 8.5" RG-178 coax cable. This antenna can be used with plastic or metal enclosures.



ORDERING INFORMATION

PART #	DESCRIPTION
ANT-868/916-PML	PML Perm. 90° Tilt

ANTENNA FACTOR CONNECTORIZED ANTENNAS

CW SERIES ANTENNAS

The CW Series antennas deliver outstanding performance in a rugged and cosmetically-attractive package. These antennas feature an FCC Part 15-compliant RP-SMA connector. This simplifies packaging and shipment, allowing for easy field replacement while complying with FCC requirements. A wide variety of matching connectors allows for numerous mounting options. The CW Series comes standard in black, but custom colors are available with a 5,000 piece minimum order. The 2.4GHz version is 1/2-wave, the rest are 1/4-wave.

Features

- Low cost
- Outstanding VSWR (<1.2 typ.)
- Excellent performance
- Omni-directional pattern
- Flexible main shaft
- Fully weatherized
- Rugged & damage-resistant
- Part 15 compliant RP-SMA connector or SMA connector
- Available in black or custom colors
- Use with plastic* or metal enclosures

* Requires proximity ground plane

ORDERING INFORMATION

PART #	DESCRIPTION
ANT-***-CW-QW-XXX	CW Connectorized Whip
*** = 418, 433, 868, 916MHz, 2.4GHz	
xxx = Blank for RP-SMA connector, SMA for SMA	



8 ANTENNAS

ANTENNA FACTOR CONNECTORIZED ANTENNAS

RH SERIES ANTENNAS

The RH Series is designed to offer near straight monopole performance in an ultra-compact package. This is ideal for small products where cosmetic or functional requirements dictate a compact, aesthetically pleasing antenna package. Despite their tiny size, RH Series antennas are ruggedly constructed and able to withstand punishing environments just like our larger whips.

Features

- Reduced-height helical whip
- Low VSWR
- SMA or Part 15 compliant RP-SMA connector
- Excellent performance
- Omni-directional pattern
- Fully weatherized
- Rugged construction
- Damage-resistant
- Use with plastic* or metal enclosures

* Requires proximity ground plane



Actual Size

ORDERING INFORMATION

PART #	DESCRIPTION
ANT-***-CW-RH-XXX	RH Reduced Height
*** = 315, 418, 433, 868, 916MHz, 2.4GHz	
xxx = Blank for RP-SMA connector, SMA for SMA	

ANTENNAS 8

HD SERIES ANTENNAS

The HD Series sets new standards for field durability. This reduced-height 1/4-wave antenna is ready for years of use thanks to a highly flexible internal helical that is overmolded with a heavy-duty protective jacket. The HD Series is an excellent choice for outdoor applications or for use in adverse environments where the antenna must resist shock, harsh weather, and tampering. The HD Series uses a Part 15 compliant RP-SMA connector.

Features

- Part 15 compliant RP-SMA connector
- Reduced-height helical whip
- Low VSWR
- Excellent performance
- Omni-directional pattern
- Flexible main shaft
- Extra-heavy-duty construction
- Fully weatherized
- Damage-resistant
- Use with plastic* or metal enclosures

* Requires proximity ground plane



ORDERING INFORMATION

PART #	DESCRIPTION
ANT-***-CW-HD	HD Heavy-Duty Reduced-Height
*** = 315, 418, 433, 868, 916MHz	

ANTENNA FACTOR CONNECTORIZED ANTENNAS

HW SERIES ANTENNAS

HW Series antennas deliver outstanding performance in a rugged and cosmetically attractive package. The 315MHz, 418MHz and 433MHz monopole versions have a 1/4-wave element. The 868MHz, 916MHz, 1.4GHz and 2.4GHz dipole versions have a center-fed 1/2-wave element with an internal ground reference. The antennas attach via a standard SMA or Part 15 compliant RP-SMA connector. Custom colors and connectors are available for volume OEM customers.

Features

- Low cost
- Outstanding VSWR
- Internal counterpoise*
- Omni-directional pattern
- Rugged construction
- Damage-resistant
- Standard SMA or Part 15 compliant RP-SMA connector
- Use with plastic** or metal enclosures

ORDERING INFORMATION

PART #	DESCRIPTION
ANT-***-CW-HW-xxx	HW Connectorized Dipole
*** = 315, 418, 433, 868, 916MHz, 1.4GHz, 2.4GHz	
xxx = Blank for RP-SMA connector, SMA for SMA	

* 868, 916MHz feature internal counterpoise

** 315, 418, 433MHz require proximity ground plane



8 ANTENNAS

CT SERIES ANTENNAS

The CT 1/2-wave 2.4GHz antenna delivers outstanding performance in a rugged and cosmetically-attractive package. The antenna's internal counterpoise eliminates external ground plane dependence and maximizes performance. CT Series antennas attach using a standard SMA or Part 15 compliant RP-SMA connector, though alternate connectors and custom colors are available for volume OEM customers.

Features

- Internal counterpoise
- Excellent performance
- Omni-directional pattern
- Very low VSWR
- Fully weatherized
- Rugged & damage-resistant
- Standard SMA or Part 15 compliant RP-SMA connector

ORDERING INFORMATION

PART #	DESCRIPTION
ANT-2.4-CW-CT-xxx	CT Connectorized Dipole
xxx = RPS for RP-SMA connector, SMA for SMA	



ANTENNA FACTOR CONNECTORIZED ANTENNAS

HWR SERIES ANTENNAS

HWR Series antennas deliver outstanding performance in a rugged and cosmetically attractive package. The articulating base allows the antenna to tilt 90 degrees and rotate 360 degrees. The 315MHz, 418MHz and 433MHz versions have a 1/4-wave element. The 868MHz, 916MHz, 1.4GHz and 2.4GHz versions have a center-fed 1/2-wave element with an internal ground reference. The antennas attach via a standard SMA or Part 15 compliant RP-SMA connector. Custom colors and connectors are available for volume OEM customers.

Features

- Low cost
- Tilts and rotates
- Standard SMA or Part 15 compliant RP-SMA connector
- Omni-directional pattern
- Outstanding VSWR
- Flexible main shaft
- Rugged & damage-resistant
- Use with plastic* or metal enclosures

*315, 418, 433MHz require proximity ground plane

*868, 916MHz, 1.4GHz and 2.4GHz feature internal counterpoise



ORDERING INFORMATION

PART #	DESCRIPTION
ANT-***-CW-HWR-xxx	HWR Right-Angle Articulating
*** = 315, 418, 433, 868, 916MHz, 1.4GHz, 2.4GHz	
xxx = RPS for RP-SMA connector, SMA for SMA	

ANTENNAS 8

RCT SERIES ANTENNAS

The RCT 1/2-wave 2.4GHz antenna delivers outstanding performance and maximum orientation flexibility in a compact physical package. The antenna's innovative articulating base allows it to tilt and swivel for optimum orientation. It mounts quickly via a Part 15 compliant RP-SMA connector.

Features

- Tilts and rotates
- Part 15 compliant right-angle RP-SMA or SMA connector
- Fully weatherized & damage-resistant
- Use with plastic or metal enclosures
- Very low VSWR
- Excellent performance
- Omni-directional pattern
- Rugged construction



ORDERING INFORMATION

PART #	DESCRIPTION
ANT-2.4-CW-RCT-xx	RCT Right-Angle Half-Wave
xx = RP for RP-SMA connector, SS for SMA	

ANTENNA FACTOR CONNECTORIZED ANTENNAS

RCS SERIES ANTENNAS

The RCS Series is ideally suited for products requiring an attractive, yet compact antenna in a right-angle form factor. The 1/4-wave antenna features a Part 15 compliant RP-SMA connection that mates with all Connector City PCB and chassis RP-SMA connectors.

Features

- Reduced-height helical whip
- Very low VSWR
- Excellent performance
- Omni-directional pattern
- Rugged construction
- Part 15 compliant right-angle RP-SMA or SMA connector
- Use with plastic* or metal enclosures

* Requires proximity ground plane



Actual Size

ORDERING INFORMATION

PART #	DESCRIPTION
ANT-***-CW-RCS-xxx	Rt-Angle Reduced-Height w/ RP-SMA
*** = 315, 418, 433, 868, 916MHz, 2.4GHz	
xxx = Blank for RP-SMA connector, SMA for SMA (2.4GHz only)	

RCL SERIES ANTENNAS

The RCL Series is similar to the RCS Series above, but in a larger form factor. It is useful in products where additional height above the product's case is needed or a slightly wider operational bandwidth is desired. The 2.4GHz version has a center-fed 1/2-wave element with internal ground reference. The 916MHz version is 1/4-wave.

Features

- Part 15 compliant right-angle RP-SMA connector
- Fully weatherized & damage-resistant
- Reduced-height whip
- Excellent performance
- Omni-directional pattern
- Rugged construction
- Use with plastic* or metal enclosures

* 916MHz Requires proximity ground plane



ORDERING INFORMATION

PART #	DESCRIPTION
ANT-***-CW-RCL	RCL Right-Angle Compact
*** = 916, 2.4GHz	

ANTENNA FACTOR CONNECTORIZED ANTENNAS

ANTENNAS 8

RAH SERIES ANTENNAS

The RAH Series is ideal for products requiring an ultra-compact, aesthetically pleasing antenna in a right-angle form factor. These antennas feature a Part 15 compliant RP-SMA connector. This simplifies packaging and shipment and allows for easy field replacement while complying with FCC requirements. The RAH Series comes standard in black, but custom colors are available for volume OEMs.

Features

- Low cost
- Outstanding VSWR
- Excellent Performance
- Part 15 compliant right-angle RP-SMA connector
- Omni-directional pattern
- Flexible main shaft
- Fully weatherized
- Rugged & damage-resistant
- Use with plastic* or metal enclosures

* Requires proximity ground plane



Actual Size

ORDERING INFORMATION	
PART #	DESCRIPTION
ANT-***-CW-RAH-XXX	RAH Reduced Height
*** = 315, 418, 433, 868, 916MHz, 2.4GHz	
xxx = Blank for RP-SMA connector, SMA for SMA (2.4GHz only)	

RAF SERIES ANTENNAS

The RAF dual-band 2.45GHz and 5.8GHz 1/2-wave antenna from Antenna Factor delivers outstanding performance at either or both of its frequencies and maximum orientation flexibility in a compact physical package. The antenna's innovative articulating base allows it to tilt and swivel for optimum orientation. It mounts quickly via a Part 15 compliant RP-SMA connector.

Features

- Tilts and rotates
- Dual-band 2.45GHz and 5.8GHz
- Very low VSWR
- Part 15 compliant RP-SMA or SMA connector
- Fully weatherized & damage-resistant
- Omni-directional pattern
- Rugged construction
- Use with plastic* or metal cases

* Requires proximity ground plane



ORDERING INFORMATION	
PART #	DESCRIPTION
ANT-DB1-RAF-xxx	RAF Dual Band
xxx = Blank for RP-SMA connector, SMA for SMA	

ANTENNA FACTOR EMBEDDED ANTENNAS

SP SERIES ANTENNAS

The Splatch uses a grounded-line technique to achieve outstanding performance from a tiny surface-mount element. This unique antenna is designed for hand or reflow mounting directly to a product's circuit board. Its low cost makes it ideal for volume applications. Unlike many compact antennas, the Splatch exhibits good proximity performance, making it an appropriate choice for hand held applications, such as remote controls, pagers, and alert devices. Typical performance is below that of many external antennas, but the Splatch is an excellent choice when cosmetic or mechanical issues dictate the use of an internal antenna.



Features

- Ideal for concealed internal mounting
- Suitable for hand or reflow assembly
- Ideal for compact portable devices
- Very low cost
- Resistant to proximity effect
- Direct PCB attachment
- Ultra-compact package

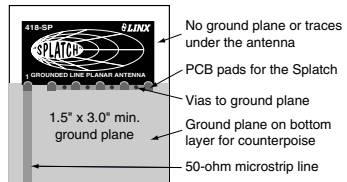

ORDERING INFORMATION

PART #	DESCRIPTION
ANT-***-SP	Spatch Planar Antenna
*** = 315, 403, 418, 433, 458, 868, 916MHz	
Spatch antennas are supplied in tubes of 20 pcs.	

JJB SERIES ANTENNAS

The JJB Series antenna packs the performance of a conventional monopole into an incredibly tiny 7mm-diameter package. This antenna is ideal for any OEM application requiring a compact, cosmetically-attractive, low-cost antenna solution. The antenna features a through-hole feedline that attaches directly to a user's PCB. Internal or external mounting is possible. JJB antennas are designed for 50-ohm systems and typically exhibit a VSWR of less than 2.0.



Features

- Good usable bandwidth (900-930MHz)
- High-performance (-1.0dBi Typical)
- Easily concealed Internally
- Ultra-compact
- Very low cost
- Low VSWR
- Direct PCB mount

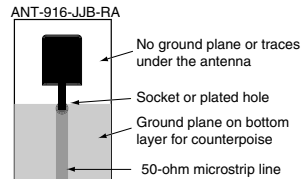

ORDERING INFORMATION

PART #	DESCRIPTION
ANT-***-JJB-RA	Right Angle JJB Perm. Ultra-Miniature
ANT-***-JJB-ST	Straight JJB Perm. Ultra-Miniature
*** = 868, 916MHz, 2.4GHz	

8 ANTENNAS

JJB-HT SERIES ANTENNAS



The popular JJB series antennas are now available in a high-temperature, reflow-compatible housing – the JJB-HT. Designed for both hand and automated assembly, the antennas are RoHS compliant and can withstand reflow processing temperatures up to 260°C. These compact monopole antennas are an ideal solution for OEM applications requiring a low-cost internal or external antenna solution. JJB-HT series antennas are supplied in tape and reel packaging.



Features

- Reflow compatible
- Low cost
- Ultra-compact package
- Easily concealed internally
- Omnidirectional pattern
- Supplied in tape and reel
- Good for internal or external mounting
- Use with plastic* or metal enclosures

* Requires proximity ground plane

ORDERING INFORMATION	
PART #	DESCRIPTION
ANT-***-JJB-HT-T	JJB High Temp. Perm. Mt., Miniature
*** = 868, 916MHz	

CHP SERIES ANTENNAS

CHP Series antennas are among the smallest and most efficient embeddable antennas available. These favorable characteristics result from the antenna's advanced multilayer LTCC design. The antenna's advanced multilayer LTCC design. The antennas are matched to 50 ohms, making them ideal for interface with both modular or discrete designs. The incredibly compact SMD package is fully compatible with both hand- and automated-reflow processes, allowing a smooth transition from prototyping to volume production. Versions are available to cover popular frequency ranges worldwide, including 2.4GHz, 868MHz and 916MHz. The size, stability and cost effectiveness of CHP Series antennas make them a logical choice for a wide range of applications

Actual Size

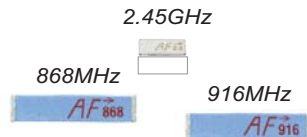

Features

- Incredibly compact SMD package
- Superior LTCC technology
- Low Loss and Wide bandwidth
- Favorable linear polarization
- > Unity gain
- Highly stable over temp. and humidity
- Hand- and reflow-assembly compatible
- Cost-effective

ORDERING INFORMATION	
PART #	DESCRIPTION
ANT-***-CHP-x	Ultra-Compact Chip Antenna
*** = 868, 916MHz, 2.4GHz	
x = "T" for Tape/Reel, "B" for Bulk	
Standard Reel is 1,500pcs (2.4GHz) or 3,000pcs (868 & 916MHz)	
Quantities less than reel size are supplied in bulk.	

HE SERIES ANTENNAS

HE Series antennas are designed for direct PCB mounting. Thanks to their compact size, they are ideal for internal concealment inside a product's housing. They are also very low in cost, making it well-suited to high-volume applications. HE Series antennas have a very narrow bandwidth (approximately 10MHz), so care in placement and layout is required. They are not as efficient as whip-style antennas, so they are generally better suited to use on the transmitter end where attenuation is often required anyway. Use on both transmitter and receiver ends is recommended only in instances where a short range (<30% of whip style) is acceptable.



Features

- Very low cost
- Compact for easy concealment
- Low physical impedance
- Rugged phosphor-bronze construction
- Precision-wound for consistent performance
- Surface-mount or through-hole styles
(element dia. 0.050")

ORDERING INFORMATION	
PART #	DESCRIPTION
ANT-***-HETH	HE Helical Through-Hole
ANT-***-HESM	HE Helical Surface-Mount
*** = 315, 418, 433, 916MHz	

ABOUT STICK-ON ANTENNAS

These antennas are designed for mounting on flat, non-conductive surfaces such as windows, drywall, ceiling tiles, plastic, etc. Their compact size and unobtrusive appearance make them well-suited to a wide range of applications from automotive interiors to in-building networks.

MHW SERIES STICK-ON ANTENNAS

The MHW Series antennas provide a clever solution for difficult environments such as vehicles. Designed to mount directly to surfaces such as window glass, rear-view mirrors, walls, and other flat non-conductive surfaces, these compact antennas are easily concealed. Three frequencies are available to cover a wide variety of applications. The antennas are well suited to low-power devices, but are capable of operation at levels to 10 watts. They are supplied with 6.5 feet or 15 feet of RG-174 coax terminated in a Part 15 compliant RP-SMA or SMA connector. Custom cable length and terminations are available for volume OEMs.



ANTENNAS 8

Features

- Typical gain 2dBi
- Very low VSWR
- Excellent performance
- Omni-directional pattern
- Flexible shafts
- Rugged damage-resistant construction
- Part 15 compliant RP-SMA connector

ORDERING INFORMATION

PART #	DESCRIPTION
ANT-***-MHW-RPS-x	MHW Center-Fed Dipole w/ RP-SMA
ANT-***-MHW-SMA-x	MHW Center-Fed Dipole w/ SMA
*** = 418, 433, 916MHz	
x = S (short 78" cable), L (long 180" cable)	

HDP SERIES TRI-BAND STICK-ON ANTENNAS

The HDP Series is a compact, center-fed antenna that achieves efficient operation at any or all of three frequency bands. Its durable, unobtrusive housing attaches permanently with integral adhesive to flat, non-conductive surfaces such as windows, drywall, ceiling tiles, plastic, etc. The antenna is supplied with 9.8 feet (3m) of highly flexible RG-174 cable.



Features

- Tri-band (824-960MHz, 1.71-1.99GHz, 2.40-2.48GHz)
- Typical gain 3dBi
- Low VSWR
- Excellent performance
- Omni-directional pattern
- Part 15 compliant RP-SMA connector
- Rugged damage-resistant construction

ORDERING INFORMATION

PART #	DESCRIPTION
ANT-DB1-HDP-xxx	HDP Surface-Mount Antenna
xxx = SMA, RPS, TNC	

VDP SERIES TRI-BAND STICK-ON ANTENNAS

The VDP Series is similar to the HDP Series, but the cable enters from the bottom to facilitate vertical orientation. In addition, this compact center-fed antenna achieves efficient operation at any or all of three frequency bands. Its durable, unobtrusive housing attaches permanently with integral adhesive to flat non-conductive surfaces such as windows, drywall, ceiling tiles, plastic, etc. The antenna is supplied with 9.8 feet (3m) of highly flexible RG-174 cable.



Features

- Tri-band (824-960MHz, 1.71-1.99GHz, 2.40-2.48GHz)
- Typical gain 3dBi
- Low VSWR
- Excellent performance
- Omni-directional pattern
- Part 15 compliant RP-SMA connector
- Rugged damage-resistant construction

ORDERING INFORMATION

PART #	DESCRIPTION
ANT-DB1-VDP-xxx	VDP Tri-Band Antenna
xxx = SMA, RPS, TNC	

DUAL-BAND THROUGH-HOLE MOUNT ANTENNAS

These compact antennas offer excellent performance in a durable and unobtrusive housing. RMT antennas combine outstanding performance with a futuristic appearance. The antennas may be operated at either or both of two frequency bands. These antennas are intended for mounting on a metal surface such as an auto deck lid.

Features

- Dual-band (860-960MHz and 1.71-1.88GHz)
- Through-hole mount
- Low VSWR
- Excellent performance
- Omni-directional pattern
- Fully weatherized
- Durable construction



RMS

RMT

ORDERING INFORMATION

PART #	DESCRIPTION
ANT-DB1-RMS-xxx	RMS Through-Hole Antenna
ANT-DB1-RMT-xxx	RMT Through-Hole Antenna
xxx = SMA for SMA connector, RPS for RP-SMA connector, TNC for TNC	

WRT SERIES ANTENNAS

The WRT Series antenna is ideally suited for applications such as wireless vending, security, traffic, or power equipment which require an unobtrusive, tamper-resistant antenna solution. The tiny 19 x 11mm radome (868, 916MHz and 2.4GHz) and 19 x 27mm radome (418 and 433MHz) install through a small hole on the product and are anchored by a threaded base. An adhesive foam compression ring is used to resist the elements. The antenna also features an integral counterpoise, which eliminates the need for a proximity ground plane. The antenna's coax feed is available with SMA or RP-SMA terminations. Alternate coax lengths, connectors and custom colors are available for volume OEM customers.



NEW

Features

- Low cost
- Unobtrusive
- Tamper resistant
- Integral counterpoise
- Indoor / outdoor
- Adhesive or permanent mount



ORDERING INFORMATION

PART #	DESCRIPTION
ANT-***-WRT-xxx	WRT Low Profile Antenna
*** = 418, 433, 868, 916MHz, 2.4GHz	
xxx = SMA (SMA) or RPS (RP-SMA) connector, UFL (U.FL) connector (868MHz, 916MHz, and 2.4GHz only)	

ANTENNAS 8

WRT-MON ANTENNA



The WRT-MON Series monopole antenna is compact and tamper-resistant. It's great for applications like wireless vending machines, traffic equipment and power equipment where space is limited and security is important.

Unlike the WRT Series dipole antenna, the WRT-MON Series monopole antenna requires a proximity ground plane, which dramatically reduces the space required inside the product. The antenna installs through a small hole on the product and is anchored by a threaded metal base connected to the coax cable shield. An adhesive foam compression ring resists the elements.

The WRT-MON Series antenna is available in 2.45GHz. It's attached to an 8.5in long coax cable with an RP-SMA, SMA or U.FL/MHF-compatible connector on the other end. The RP-SMA and SMA connectors use an RG-174 coax. The U.FL/MHF connector uses a 1.32mm micro-coax. More connectors, colors and coax length options are available for OEM customers.



Features

- Low cost
- Unobtrusive
- Tamper resistant
- Indoor / outdoor

ORDERING INFORMATION

PART #	DESCRIPTION
ANT-2.4-WRT-MON-xxx	WRT-MON Low Profile Antenna
xxx = SMA (SMA) or RPS (RP-SMA) connector, UFL (U.FL) connector	

ANTENNA FACTOR MAGNETIC MOUNT ANTENNAS

MAGNETIC-MOUNT ANTENNA SYSTEM

The magnetic mount system allows customers to select from among 40, 66, or 85mm bases which contain a powerful magnet suitable for semi-permanent installation on metal surfaces. The base is covered with a thin protective layer to protect finished surfaces such as those on automobiles. Completing the system is a variety of interchangeable elements covering frequencies from 824MHz to 2.4GHz with gains to 9dBi. The base is supplied with a 13.1' coax terminated in a RP-SMA or TNC connector. Other cable terminations are available for volume OEM orders.



ANTENNAS 8

Part #	S01-005	S01-006	S01-008	S01-010	S01-011	S01-012
Frequency	860-960MHz	824-960MHz	824-960MHz 1.7-1.8GHz	860-960MHz	2.4GHz	824-896MHz 1.9GHz
Gain	3dBi	5dBi	3dBi	0dBi	0dBi	5dBi

ORDERING INFORMATION

PART #	DESCRIPTION
ANT-ELE-S01-005	Whip Element
ANT-ELE-S01-006	High-Gain Whip Element
ANT-ELE-S01-008	Dual-Band Whip Element
ANT-ELE-S01-010	Short Whip Element
ANT-ELE-S01-011	Stub Element
ANT-MAG-B##-xxx	Mag-1 Series Bases
## = Base Diameter: 50, 66, 85mm	
xxx = Cable Termination: RPS or TNC	
Comes standard in black	

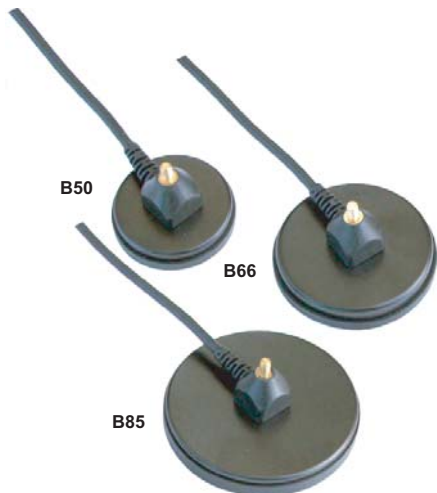

ABOUT GPS ANTENNAS

GPS capabilities are being integrated into a diverse array of products. As with any RF system, the antenna plays a critical role in the performance and reliability of the product. Antenna Factor offers a variety of high-performance, low-cost GPS antennas to meet the needs of this rapidly expanding market. Additional cable terminations are available to volume OEM customers by special order.

UC SERIES ANTENNAS

UC Series GPS antennas deliver high-gain, low-noise performance in a rugged and cosmetically attractive package. They feature a wide operating temperature, wide operating voltage, and low current consumption. The antennas attach via a standard SMA, Part 15 compliant RP-SMA, or MCX connector.

Features

- Compact
- High-gain, low-noise design
- Low current consumption
- Wide operating voltage
- Wide operating temperature
- Fully weatherized
- Rugged & damage-resistant
- Magnetic mount



ORDERING INFORMATION	
PART #	DESCRIPTION
ANT-GPS-UC-xxx	UC Series GPS Antenna
xxx = RPS, SMA, MCX	

SH SERIES ANTENNAS

SH Series GPS antennas combine superior performance, advanced operational and protection features, and low power consumption. For maximum compatibility with the host receiver, the SH accepts supply voltages from +2.5VDC to +12VDC and is protected against shorts, over current, or reverse polarity situations. The antennas attach via a SMA, MCX, or MMCX connector.

Features

- Compact
- High-gain, low-noise design
- Low current consumption
- Wide operating voltage
- Protection circuit
- Wide operating temperature
- Fully weatherized
- Rugged & damage-resistant
- Magnetic mount



ORDERING INFORMATION	
PART #	DESCRIPTION
ANT-GPS-SH-xxx	ST Series GPS Antenna
xxx = SMA, MCX, MMCX	

YAGI ANTENNAS

Antenna Factor offers Yagi antennas in models covering frequencies from 400MHz to 2.4GHz. The antennas are designed for long-distance directional communication and can greatly enhance the performance of RF links. Made of stainless steel and featuring sturdy mast mounts, these rugged antennas are constructed to withstand the stress of long-term use. All antennas are designed for 50-ohm system matches with a maximum input of 100W. See Linx Technologies for stock extension cables.

**NOTE* Use of these antennas may result in TX and RX emission levels in excess of legal limits.*



Features

- High-gain
- Stainless steel construction
- Fully weatherized
- Rugged & damage-resistant
- RG-8/U cable with female N connector

ANTENNAS 8

ORDERING INFORMATION

PART #	DESCRIPTION
ANT-2.4-YG6-N	2.4GHz 6-Element Yagi Antenna
ANT-2.4-YG12-N	2.4GHz 12-Element Yagi Antenna
ANT-916-YG5-N	916MHz 5-Element Yagi Antenna
ANT-418-YG5-N	418MHz 5-Element Yagi Antenna

OMNIDIRECTIONAL ANTENNAS



The OM Series of gain antennas are designed to increase the range and reliability of wireless links while maintaining an omnidirectional pattern around the circumference of the antenna. This characteristic allows for greater flexibility in the placement of system devices than is often found in typical gain antenna solutions. OM Series antennas also feature rugged, weatherized construction making them well suited for both indoor and outdoor applications. The antenna includes complete mounting hardware for standard masts. The standard antenna features 7dBi gain. Higher gain versions are available upon request.

**NOTE* Use of these antennas may result in TX and RX emission levels in excess of legal limits.*

Features

- High-gain
- Fiberglass radome construction
- Fully weatherized
- Rugged & damage-resistant
- N connector

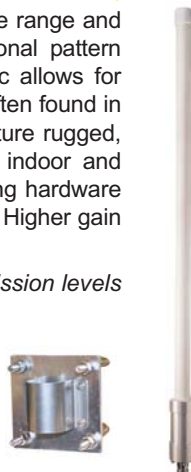

ORDERING INFORMATION	
PART #	DESCRIPTION
ANT-2.4-OM-CM-01-N	2.4GHz Gain Antenna

OMNIDIRECTIONAL ANTENNAS



The OM-DW Series ceiling mount, omnidirectional antenna provides a wide bandwidth performance in an omnidirectional pattern. Covers bandwidths of 860-960MHz, 1.70-2.00GHz, 2.40-2.48GHz, 3.40-3.60GHz and 5.72-5.88GHz. Its attractive smooth, streamlined profile is suitable for office, industrial or home environments. Mounting and connection are through a single access hole in the mounting surface.



Features

- Omnidirectional pattern
- Moderate gain
- Attractive appearance
- Rugged & damage-resistant
- N female connector
- Excellent performance over common frequency ranges

ORDERING INFORMATION	
PART #	DESCRIPTION
ANT-DB1-OM-DW-01-N	Multi-band, Omnidirectional Antenna

LOG PERIODIC ANTENNAS



The Log Periodic antenna is designed for long-distance directional communication over a wide range of frequencies. The DB1-LP antenna provides gain and directivity comparable to a Yagi, but in a much smaller overall form factor, and over a considerably wider range of frequencies. Covers bandwidths of 824-960MHz, 1.71-2.17GHz, 2.40-2.48GHz. Constructed of UV stabilized materials, the antenna is suitable for long-term use in indoor or outdoor environments. The antenna includes complete mounting hardware for standard masts.



**NOTE* Use of these antennas may result in TX and RX emission levels in excess of legal limits.*

ANTENNAS 8

Features

- High gain
- Wide bandwidth
- Fully weatherized
- Rugged & damage-resistant
- N female connector
- Excellent performance over common frequency ranges

ORDERING INFORMATION	
PART #	DESCRIPTION
ANT-DB1-LP-RM-01-N	Tri-Band Log Periodic Antenna

PANEL ANTENNAS



The PN Series of panel mount antennas are designed for long distance directional communication of wireless links. Gain and directivity are superior to typical Yagi antennas, increasing the range and reliability of your wireless link. The antennas feature rugged, weatherized construction making them well suited for both indoor and outdoor applications. Each antenna includes complete mounting hardware for standard masts.



**NOTE* Use of these antennas may result in TX and RX emission levels in excess of legal limits.*

Features

- High gain
- Excellent directivity
- Fully weatherized
- Rugged & damage-resistant
- N female connector

ORDERING INFORMATION	
PART #	DESCRIPTION
ANT-2.4-PN-SM-01-N	2.45GHz Panel Mount Antenna

ANT-SKINS ANTENNA COVERS

These low-cost sleeves provide the external ruggedness and cosmetic appeal of expensive whip antennas, but are hollow to cover the low-cost internal element of a user's choosing, such as a wire, rod, or flexible shaft. The sleeve is designed to allow a wide range of mounting options in metal or plastic housings of various thicknesses. Ant-Skins can also reduce your parts inventory, since a wide range of frequency lengths can be accommodated by a single sleeve.



Features

- Recesses provided to accommodate six different thicknesses of case materials by simply pulling the Ant-Skin through the case until it is in the correct position.
- Squared base for permanent spin-proof mounting option
- Generous cavity to accommodate many different elements including flexible cable, wire, or rod.
- Cost-effective.
- Cosmetically-attractive, professional appearance.



The multi-purpose base allows mounting in a hole, clamp, or molded-slot configuration.

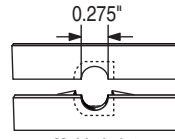
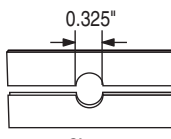
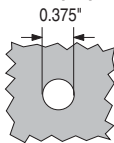

Through-Hole Mounting

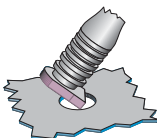

Hook base through hole



Rock & rotate to step down to correct position

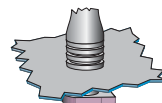

When correct level for material is reached, center ant-skin

ORDERING INFORMATION

PART #	DESCRIPTION
ANT-SKN-V1-***	Ant-Skin Antenna Cover
*** = 1.50, 3.15, 4.25 inches	

CONNECTORIZED ANTENNA EVALUATION KIT

Compare whip-antenna styles & performance!

This handy kit contains two of each whip-antenna style at the frequency of your choice, plus a sampling of Linx RP-SMA or SMA connectors.

Kit Includes

- 2 RH Reduced-Height
- 2 HD Heavy-Duty
- 2 HW Connectorized
- 2 HWR Articulating Connectorized
- 2 CW Connectorized
- 2 RCS Right-Angle
- 2 RAH Right-Angle

- RP-SMA Connectors
 - ◆ 2 Right-Angle
 - ◆ 2 Vertical PCB
 - ◆ 2 Bulkhead
 - ◆ 2 PCB Edge-Mount
 - ◆ 2 Multi-Mount



ORDERING INFORMATION

PART #	DESCRIPTION
CAEK-***	Connectorized RP-SMA Antenna Eval Kit
*** = Center 418, 433, 868, 916MHz, 2.4GHz	

ANTENNAS 8

Kit Includes

- 2 RH Reduced-Height
- 2 HW Connectorized
- 2 HWR Articulating Connectorized
- 2 CW Connectorized

- SMA Connectors
 - ◆ 2 Right-Angle
 - ◆ 2 Vertical PCB
 - ◆ 2 Bulkhead
 - ◆ 2 PCB Edge-Mount
 - ◆ 2 Multi-Mount



ORDERING INFORMATION

PART #	DESCRIPTION
CAEK-***-SMA	Connectorized SMA Antenna Eval Kit
*** = Center 418, 433, 868, 916MHz, 2.4GHz	

ANTENNA FACTOR ANTENNA EVALUATION KITS

PERMANENT-MOUNT ANTENNA EVALUATION KIT

Compare whip-antenna styles & performance!

This handy kit contains two of each permanent-mount 1/4-wave antenna style at the frequency of your choice.

Kit Includes

- Quarter-Wave Whip
- 2 PW-QW Perm. Mount w/coax
- 2 LP Reduced-Height
- 2 RA Right-Angle - Tilt-Swivel
- 2 SP SMD Planar
- 2 JJB Ultra-Miniature*
 - * 916, 868MHz and 2.4GHz only



ORDERING INFORMATION

PART #	DESCRIPTION
PAEK-***	Permanent-Mount Antenna Eval Kit

*** = Center 418, 433, 868, 916MHz, 2.4GHz

8 ANTENNAS

CHIP ANTENNA EVALUATION KIT

This handy kit contains six chip antennas and a test board to allow you to evaluate the performance of the chip antenna.

Kit Includes

- 6 Chip Antennas*
- 1 Evaluation Board
- Antenna Data Guide

* Listed quantity includes those populated on test board



ORDERING INFORMATION

PART #	DESCRIPTION
AEK-***-CHP	Chip Antenna Evaluation Kit

*** = 868, 916MHz, 2.45GHz

ANTENNA FACTOR ANTENNA EVALUATION KITS

SP SERIES ANTENNA EVALUATION KIT

This handy kit contains six SP Series antennas and a test board to allow you to evaluate the performance of the antenna.

Kit Includes

- 6 SP Series Antennas*
- 1 Evaluation Board
- Antenna Data Guide

* Listed quantity includes those populated on test board



ORDERING INFORMATION

PART #	DESCRIPTION
AEK-***-SP	SP Series Antenna Evaluation Kit
*** = 315, 403, 418, 433, 458, 868, 916MHz	

Helping You Bring Your Product To Life

An engineer will generally choose most components based on technical issues of function and application. RF products are unusual in that they involve not only such technical issues, but issues of legality as well. Many manufacturers have avoided incorporating RF into their products as a result of uncertainty and even fear of such matters.

In order to address these concerns and simplify each customer's design cycle, Linx has attempted to identify any step in the RF implementation process that may cause delay or frustration. We have tailored a service to simplify that step. While such services are unusual for a high-volume component manufacturer, they are all a part of the Linx commitment to "Wireless Made Simple®".

FCC PRE-SCREEN SERVICES

The most difficult obstacle to overcome when bringing an RF-based product to market, aside from the design itself, is the approval process. To ensure our customers the best opportunity to pass FCC testing, Linx offers unique low-cost pre-compliance testing services. Using our state-of-the-art Hewlett Packard EMC compliancy test system, a product is screened just as it will be during actual FCC testing. In addition to this screen, the actual design is evaluated by a Linx engineer to ensure that it is both legal and technically optimized. A pre-screen report is then generated summarizing our findings and recommendations. This report, along with additional documentation, will ease your preparations for final approval testing.

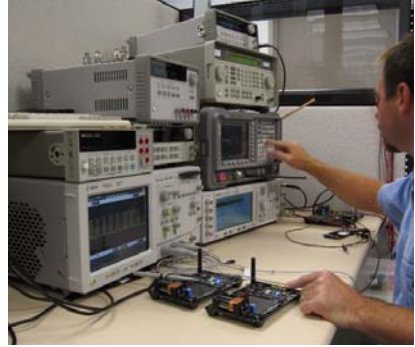

OEM MODIFICATIONS

As a rule, Linx does not undertake the design or manufacture of customer-specific products; however, many products can be modified for high-volume applications. Our OEM product lines are especially suited to such modifications. Company logos, custom colors, and nomenclature are all ways that Linx products can be adapted to meet the needs of an individual customer. Custom antennas, cables, and connectors can also be provided through Linx Technologies and Linx's Antenna Factor division.



ANTENNA DESIGN ASSISTANCE

Linx offers a wide variety of standard antenna styles that will meet the needs of most user applications. Occasionally a design will call for a custom antenna to meet physical or cosmetic constraints. Since the design of application-specific antennas calls for experience and equipment outside the scope of many of our customers, Linx offers antenna design services. These services range from assistance in evaluation of a customer's antenna configuration to design of the actual antenna.



INTERNET SITE

If you have questions regarding any Linx product and have internet access, make

www.linxtechnologies.com

your first stop. Our website is organized in an intuitive format to give you the answers you need in record time. Day or night, the Linx website gives you instant access to the latest information regarding the products and services of Linx.

It's all here: manual and software updates, application notes, FCC information, and much more. Be sure to visit soon!



IMPLEMENTATION ASSISTANCE

Our engineers have broad experience in almost every area of design and manufacturing. Linx is pleased to offer our customers the benefit of that experience as it pertains to the integration of Linx RF products into a product design. Through our Apex Wireless division, Linx also offers a full range of design services.



EDUCATION

At Linx, we believe that our best customer is an informed customer. That is why our comprehensive manuals are supported by a growing library of informative Application Notes. These notes are designed to provide guidance on the effective implementation of Linx products across a broad range of applications. Many different topics are discussed in more detail than in the device data guide, from matters to consider before embarking on a design to complete overviews of legal and technical issues affecting wireless products. Backed by the assistance of experienced support personnel, each customer has an opportunity to learn about our products and the basic principles of RF whereby they work. Application Notes may be downloaded from www.linxtechnologies.com or obtained by contacting the Linx literature department.





Linx Application Notes are designed to provide guidance on the effective implementation of Linx products across a broad range of applications. Many different topics are discussed in more detail than in the device data guide, from matters to consider before embarking on a design to complete overviews of legal and technical issues affecting wireless products. This library is ever expanding and your suggestions for topics of interest are always welcomed. Please check the Linx website for additional notes that

may have become available since the date of this publication. Application Notes may be downloaded from the Linx website at www.linxtechnologies.com or obtained by contacting the Linx literature department.

APPLICATION NOTES

NUMBER	DESCRIPTION
AN-00100	RF 101 Information for the RF Challenged
AN-00125	Considerations For Operation Within the 260-470MHz Band
AN-00126	Considerations For Operation Within the 902-928MHz Band
AN-00128	Data and Bi-directional Transmissions under Part 15.231
AN-00130	Modulation Techniques For Low-Cost RF Data Links
AN-00140	The FCC Road: Part 15 From Concept To Approval
AN-00150	Use and Design of T-Attenuation Pads
AN-00155	Serial Load Techniques For The HP Series 3
AN-00156	Reading The Tx ID From The MS and HS Decoders
AN-00157	Serial Communication with the MT Series Transcoder
AN-00160	Considerations For Sending Data Over a Wireless Link
AN-00200	SDM-USB-QS-S Programmer's Guide
AN-00201	Installing the SDM-USB-QS-S Drivers
AN-00232	Considerations For Sending Data With The LC Series
AN-00300	Addressing Linx OEM Products
AN-00310	Encoder and Decoder Comparison
AN-00500	Antennas: Design, Application, and Performance
AN-00501	Understanding Antenna Specifications and Operation
FCCGD198	FCC Resource Document

11 TERMS AND CONDITIONS OF SALE

1. PAYMENT TERMS

Customer shall pay Linx in advance for all evaluation kits and orders for less than 1,000 pieces of Product. Customer shall pay all other orders for Product without setoff or deduction upon receipt of Linx's invoice, unless prior credit approval has been granted by Linx. Linx may extend NET 30 terms on approved accounts. Please complete Linx's credit application for consideration of NET 30 terms. All prices quoted or charged by Linx shall be EXW. Linx's plant. Prices do not include sales, excise, use, or other taxes measured by the sales price of Product sold. Customer shall pay any and all such taxes. Interest shall accrue on all past due amounts at the rate of 1.5% per month or the maximum allowed by law, whichever is less.

2. QUANTITY DISCOUNTS

Linx may, in its discretion, extend quantity pricing discounts to Customers with accounts in good standing based on the amount of Product purchased in a six-month period with up to four Product release dates. In the event of rescheduling or partial cancellations, Linx will retroactively invoice Customer to reflect the discount attributable for the actual amount of Product accepted.

3. EVALUATION KIT PURCHASE REQUIREMENT

Linx requires the Customer to purchase an evaluation kit prior to the sale of individual modules of Product. This policy ensures that each Customer has the tools necessary to fairly evaluate our Products and legally use them for Customer's application.

4. CANCELLATIONS

Customer may cancel an order for standard Product at any time prior to shipment by Linx. If the cancellation affects a quantity discount extended for a blanket order, Customer will be billed retroactively for the difference between the quantity of Product ordered and quantity accepted. Cancellation of an order for custom Product at any time or standard Product after shipment is not permitted.

5. CHANGES

Linx realizes Customer's needs change rapidly and will attempt to accommodate requested changes to Customer's orders. Additional charges for requested changes may apply.

6. DELIVERY

Linx will deliver the Products by placing them with a carrier for delivery to Customer. Delivery dates are estimated only. In no event shall Linx be liable to Customer or any third parties for any damages of any kind, direct or indirect, in the event of delay of delivery.

7. INSPECTION AND ACCEPTANCE

Customer shall promptly inspect and test all Products upon receipt. Customer shall be deemed to have accepted all Products unless Customer gives written notice of defective or non-conforming Products within 15 days after receipt. Customer's notice shall describe the defect or non-conformity of the Products. Repair or replacement of any Products Linx determines to be defective or non-conforming shall be in accordance with Linx's Limited Warranty and Exclusions and Customer's Remedies as provided for below.

8. RETURNS

All Product returned to Linx must be accompanied by a valid Return Merchandise Authorization Number ("RMA#"), which may be obtained by calling our Customer Service Department at (541) 471-6256. Products not bearing an RMA# will be returned at Customer's expense. Customer may return for refund or credit new, unused, non-defective, or conforming Products that were shipped within the prior 120 days subject to (a) a 15% restocking charge, or (b) no restocking charge when the return is accompanied by a new order for Product that is at least twice the invoice amount (freight, insurance, and taxes excluded) of the returned Product.

9. LIMITED WARRANTY AND EXCLUSIONS

Linx warrants that its Products will conform to Linx's current published specifications and be free of defects in materials and workmanship for 90 days from the date of purchase when used in accordance with the guidelines and parameters specified by Linx's documentation. Linx does not warrant against defects arising from improper design, application, or assembly practices, rework damage, exposure to moisture, impacts, excessive heat or cold, ESD, or overvoltage, or any other condition resulting from other than ordinary and appropriate usage.

Linx does not warrant the suitability of its Products for any specific application by Customer. **NONE OF LINX'S PRODUCTS IS INTENDED FOR USE IN APPLICATIONS IN WHICH THE SAFETY OF LIFE OR PROPERTY IS AT RISK.** Linx does not warrant any of its Products used in any application in which life or property is at risk.

10. DISCLAIMER OF OTHER WARRANTIES

LINX DISCLAIMS ALL WARRANTIES OF MERCHANTABILITY AND FITNESS FOR A PARTICULAR PURPOSE.

TERMS AND CONDITIONS OF SALE 11

11. CUSTOMER'S REMEDIES

In the event warranty service is required, an RMA# must be obtained from Linx prior to return. Linx will carefully assess Customer's returned Product. If it is found to qualify for warranty status, Linx will, at its election, repair or replace the Product without charge (excluding inbound shipping), or refund the original purchase price paid.

12. LIMITATIONS ON CUSTOMER'S REMEDIES

IN NO EVENT SHALL LINX BE LIABLE FOR ANY OF CUSTOMER'S INCIDENTAL OR CONSEQUENTIAL DAMAGES, INCLUDING, WITHOUT LIMITATION, ANY LOST PROFITS OR LOST REVENUES, ARISING IN ANY WAY FROM ANY DEFECTIVE OR NON-CONFORMING PRODUCTS OR FOR ANY OTHER BREACH OF CONTRACT BY LINX. The limitations on Linx's liability is applicable to any and all claims or theories of recovery asserted by Customer, including, without limitation, breach of contract, breach of warranty, strict liability, or negligence. Customer assumes all liability (including, without limitation, liability for injury to person or property, economic loss, or business interruption) for all claims, including claims from third parties, arising from the use of the Products.

13. LIMITATIONS ON TIME TO BRING ACTION

Any action by Customer against Linx must be commenced by Customer within one year after the cause of action has accrued.

14. LINX'S REMEDIES

Upon default by Customer, Linx shall have all the remedies afforded a seller of goods at law or in equity, including, without limitation, the right to (a) immediately accelerate all amounts due from Customer, (b) suspend shipment of all Products ordered, and (c) cancel all orders for Products.

15. INDEMNITY

Customer will indemnify, defend, protect, and hold harmless Linx from and against all claims, damages, actions, suits, proceedings, demands, assessments, adjustments, costs, and expenses incurred by Linx as a result of or arising from any Products sold by Linx to Customer.

16. FCC CERTIFICATION

Linx designs its Products taking into account compliance with FCC Part 15. HOWEVER, IT IS THE SOLE RESPONSIBILITY OF CUSTOMER TO VERIFY THE APPROPRIATENESS OF THE PRODUCTS FOR EACH INDIVIDUAL APPLICATION AND OBTAIN CERTIFICATION OF THE CUSTOMER'S COMPLETED GOODS INTO WHICH THE PRODUCTS ARE INCORPORATED.

17. PROPRIETARY INFORMATION

Linx's Products may contain proprietary, patented, or copyrighted techniques, components, or materials. Under no circumstances shall any Customer have any right, title, or interest in any of Linx's proprietary information.

18. DELAYS AND FORCE MAJEURE

Linx shall not be in default for any delay in performance or delivery caused by circumstances beyond its reasonable control, including, but not limited to, an act of God, fires, floods, wars, terror, government actions, accidents, labor troubles, labor shortages, unavailability of materials, unavailability of equipment, or unavailability of transportation ("Force Majeure Event"). Linx may, without liability to Customer, suspend or cancel its performance upon the occurrence of any Force Majeure Event without liability to Customer.

19. COMPLETE AGREEMENT

These Terms and Conditions may be changed only by a written document executed by Linx and Customer. Any order, acknowledgment, or other form of acceptance issued by Customer that modifies, conflicts with, or contradicts any provision of these Terms and Conditions is objected to and rejected by Linx.

20. CHOICE OF LAW

The parties' agreement shall be governed by the laws of the State of Oregon. For international sales, the laws of the State of Oregon, and not the United Nations Convention on Contracts for the International Sales of Goods, shall apply.

21. ARBITRATION AND ATTORNEY FEES

Any and all claims arising under these Terms and Conditions, or arising in any way from the sale or use of the Products, or otherwise, shall be resolved by binding, mandatory arbitration under the authority of the Arbitration Service of Portland before a panel of three arbitrators. The arbitration shall be conducted in Portland, OR. The prevailing party in the arbitration shall be entitled to an award of attorney fees and all other costs of arbitration against the non-prevailing party.



LINX TECHNOLOGIES

159 ORT LANE
MERLIN, OR 97532

3090 STERLING CIRCLE
SUITE 200
BOULDER, CO 80301

PHONE: (541) 471-6256

FAX: (541) 471-6251

www.linxtechnologies.com

Disclaimer

Linx Technologies is continually striving to improve the quality and function of its products. For this reason, we reserve the right to make changes to our products without notice. The information contained in this Overview Guide is believed to be accurate as of the time of publication. Specifications are based on representative lot samples. Values may vary from lot-to-lot and are not guaranteed. "Typical" parameters can and do vary over lots and application. Linx Technologies makes no guarantee, warranty, or representation regarding the suitability of any product for use in any specific application. It is the customer's responsibility to verify the suitability of the part for the intended application. NO LINX PRODUCT IS INTENDED FOR USE IN ANY APPLICATION WHERE THE SAFETY OF LIFE OR PROPERTY IS AT RISK.

Linx Technologies DISCLAIMS ALL WARRANTIES OF MERCHANTABILITY AND FITNESS FOR A PARTICULAR PURPOSE. IN NO EVENT SHALL LINX TECHNOLOGIES BE LIABLE FOR ANY OF CUSTOMER'S INCIDENTAL OR CONSEQUENTIAL DAMAGES ARISING IN ANY WAY FROM ANY DEFECTIVE OR NON-CONFORMING PRODUCTS OR FOR ANY OTHER BREACH OF CONTRACT BY LINX TECHNOLOGIES. The limitations on Linx Technologies' liability are applicable to any and all claims or theories of recovery asserted by Customer, including, without limitation, breach of contract, breach of warranty, strict liability, or negligence. Customer assumes all liability (including, without limitation, liability for injury to person or property, economic loss, or business interruption) for all claims, including claims from third parties, arising from the use of the Products. The Customer will indemnify, defend, protect, and hold harmless Linx Technologies and its officers, employees, subsidiaries, affiliates, distributors, and representatives from and against all claims, damages, actions, suits, proceedings, demands, assessments, adjustments, costs, and expenses incurred by Linx Technologies as a result of or arising from any Products sold by Linx Technologies to Customer. Under no conditions will Linx Technologies be responsible for losses arising from the use or failure of the device in any application, other than the repair, replacement, or refund limited to the original product purchase price. Devices described in this publication may contain proprietary, patented, or copyrighted techniques, components, or materials. Under no circumstances shall any user be conveyed any license or right to the use or ownership of such items.

© 2011 by Linx Technologies
The stylized Linx logo, Linx, "Wireless Made Simple", CipherLinx, and the stylized CL logo are trademarks of Linx Technologies.
Printed in U.S.A.