



# SCD12L THRU SCD14L

## SURFACE MOUNT LOW VF SCHOTTKY BARRIER RECTIFIER

Reverse Voltage - 20 to 40 Volts

Forward Current - 1.0 Amperes

**PATENTED**

2010



### FEATURES

- \* Lead free product
- \* Leadless chip form , no lead damage
- \* Lead-free solder joint , no wire bond & lead frame
- \* Plastic package has Underwriters Laboratory Flammability Classification 94V-0
- \* For surface mounted applications
- \* Low profile package
- \* Built-in strain relief
- \* Metal to silicon rectifier , majority carrier conduction
- \* Low power loss , High efficiency
- \* High current capability , Super low VF drop
- \* High surge capacity
- \* For using in low voltage high frequency switching power supply, inverters , free wheeling , and polarity protection applications

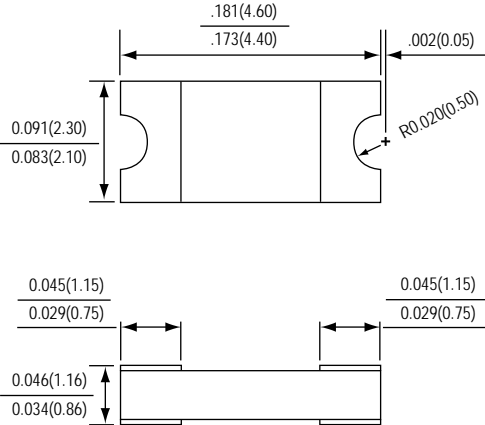

\*Dimensions in inches and (millimeters)

**SuperChip**<sup>TM</sup>

### MECHANICAL DATA

**Case** : Packed with FRP substrate and epoxy underfilled  
**Terminals** : Pure Tin plated (Lead-Free), solderable per MIL-STD-750, Method 2026.  
**Polarity** : Laser marking  
**Weight** : 0.02 gram

### MAXIMUM RATINGS AND ELECTRICAL CHARACTERISTICS

Ratings at 25 °C ambient temperature unless otherwise specified.	SYMBOLS	SCD12L	SCD14L	UNITS
Maximum repetitive peak reverse voltage	VRRM	20	40	Volts
Maximum RMS voltage	VRMS	14	28	Volts
Maximum DC blocking voltage	VDC	20	40	Volts
Maximum average forward rectified current (SEE FIG.1)	I (AV)	1.0		Amps
Peak forward surge current 8.3ms single half sine-wave superimposed on rated load (JEDEC Method)	IFSM	30		Amps
Maximum instantaneous forward voltage at 1.0 A (NOTE 1)	VF	0.36	0.38	Volts
Maximum DC reverse current (NOTE 1) @T <sub>J</sub> =25°C at rated DC blocking voltage @T <sub>J</sub> =80°C	IR	1.0		mA
		30		
Typical thermal resistance (NOTE 2)	R θJA R θJL	55 17		°C / W
Operating junction temperature range	TJ	-55 to +125		°C
Storage temperature range	TSTG	-55 to +150		°C

NOTES : (1) Pulse test width PW=300usec , 1% duty cycle.

(2) Mounted on P.C. board with 0.2 x 0.2"(5.0 x5.0mm) copper pad areas.

# RATINGS AND CHARACTERISTIC CURVES SCD12L THRU SCD14L

FIG.1 - FORWARD CURRENT DERATING CURVE

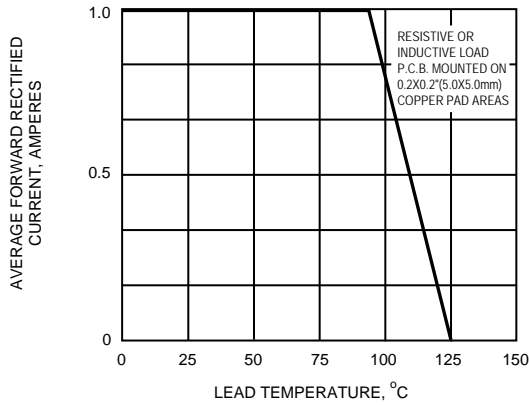

FIG.2 - MAXIMUM NON-REPETITIVE PEAK FORWARD SURGE CURRENT

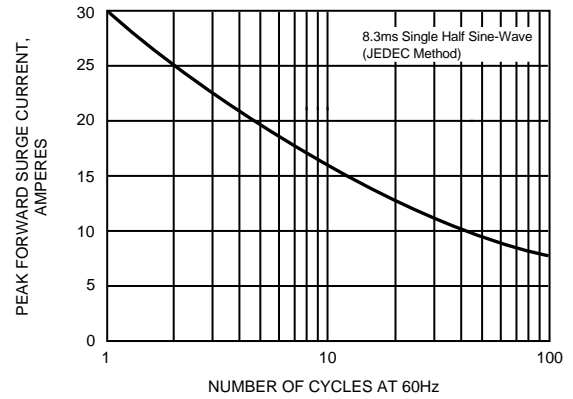

FIG.3 - TYPICAL INSTANTANEOUS FORWARD CHARACTERISTICS

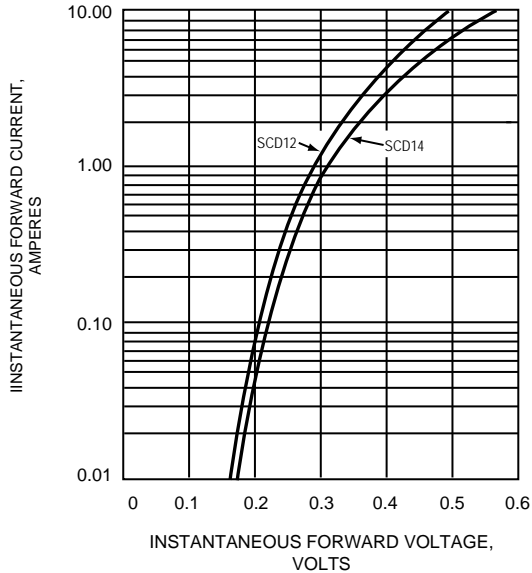

FIG.4 - TYPICAL REVERSE CHARACTERISTICS

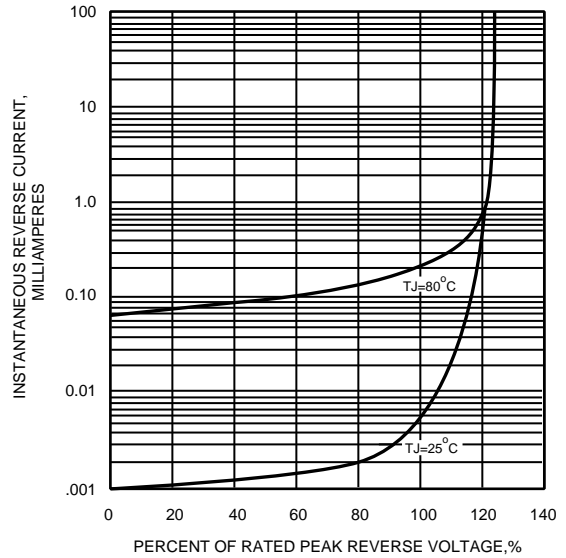

FIG.5 - TYPICAL JUNCTION CAPACITANCE

